

User Manual

Segway® Robotics Mobility Platform



SEGWAY RMP

440 SE

Contents

Copyright, Disclaimer, Trademarks, Patent, and Contact Information 5

Introduction

Safety..... 7
 Abbreviations 9

RMP 440 SE

Included Components..... 10
 Capabilities..... 11
 Coordinate System 12
 Physical Characteristics 13
 Mounting Locations 14
 User Interface Panel..... 15
 Powerbase Connections 16
 Performance Specifications 17
 Environmental Specifications..... 17
 Endurance 18
 Transportation and Shipping 20

Electrical Overview

System Architecture 21
 System Power..... 21
 System Components 22

Operational Model

Operational States 24
 Faults 24
 Initialization..... 25
 Diagnostic Mode 26
 Bootloader Mode..... 26
 Standby Mode 26
 Tractor Mode 26
 Disable Mode..... 27

Charging

Using the External Power Supply	28
Charge Status LEDs	28

Powering On/Off

Powering On	29
Powering Off	29

Connecting

Connector I	30
Starter Breakout Harness	31
Connector II	32
Disable Button	32
Additional Signals	32
Connector IV	33
Connecting To the RMP	34

Communication

General Command Structure	37
Standard Motion Commands	39
Omni Motion Commands	40
Configuration Commands	42
Controller Input Mapping	53
RMP Response	56
IEEE754 32-bit Floating Point and Integer Representation	67
Cyclic Redundancy Check (CRC)-16	68
Fault Status Definitions	72

Internal Connections

Centralized Control Unit	78
Auxiliary Battery Board	79
Smart Charger Board	80
Communication	81
Hardware Controls	87
Mode Selection	88
Status Indicators	88
CCU Input Power	89
CCU Battery Supply	89
Coin Cell Battery	89

Included Software

Installing the Software	90
RMP CCU Bootloader Application	91
OCU Demo Application	92
Software License Agreement	97

Maintenance

Fastener Torque.....	98
Tire Pressure	98
Parts List	99
Removing Wheel Assemblies.....	100
Replacing Wheel Assemblies	100
Cleaning.....	100
Software Updates.....	100

Batteries

Replacing Batteries.....	101
Installation and Removal Instructions	102
Transportation and Shipping.....	102
Proper Disposal.....	102

Troubleshooting

Reporting Problems to Segway	103
Extracting the Faultlog.....	103
Reading the Faultlog	104
Faults	105
Charging Faults	109
Other Issues	109

Copyright, Disclaimer, Trademarks, Patent, and Contact Information

Copyright © 2013 Segway Inc. All rights reserved.

Disclaimer

The Segway RMP is not a consumer product. Usage examples shown on rmp.segway.com have not necessarily been reviewed nor approved by Segway Inc. ("Segway"). Segway is not responsible for end customer modifications or additions.

Trademarks

Segway owns a number of trademarks including, but not limited to, Segway and the Segway "flyguy" logo that have been registered in the United States and in other countries. Those trademarks followed by ® are registered trademarks of Segway. All other marks are trademarks or common law marks of Segway. Failure of a mark to appear in this guide does not mean that Segway does not use the mark, nor does it mean that the product is not actively marketed or is not significant within its relevant market. Segway reserves all rights in its trademarks. All other trademarks are the property of their respective companies.

Xbox® is a registered trademark of Microsoft Corporation.

Logitech® is a registered trademark of Logitech International SA.

Segway Patent Information

The Segway RMP is covered by U.S. and foreign patents. For a patent listing, see <http://rmp.segway.com/RMPPatents.pdf>.

Contact Information

For support, please contact Segway Customer Care or use the RMP forum at <http://rmp.segway.com/forum>.

Segway Customer Care: 866-4SEGWAY (866-473-4929)

Fax: 603-222-6001

E-mail: technicalsupport@segway.com

Website: <http://rmp.segway.com>

Introduction

The Segway Robotics Mobility Platform (RMP) is a robotic vehicle chassis and power-train designed to be integrated with additional components to create robotic products. It is intended to be the mobility component for any number of robotic applications and as such was designed with versatility, durability, and performance in mind.

Segway engineers have led the way with electric drive propulsion systems in the fields of battery management, advanced sensing, drive-by-wire control, and dynamic stabilization. The RMP benefits from some of the same proprietary technology that has been deployed and proven around the world as part of the Segway Personal Transporter (PT) line of products.

The RMP can handle high payloads, a variety of environmental conditions, and a wide range of operational scenarios. The chassis is designed to handle a certain amount of abuse consistent with operation over rough terrain and in industrial environments. Control parameters can be tweaked to make it easy to drive slowly around obstacles, at high speed in open spaces, or in any environment in between.

Control of the RMP occurs via command and response messages sent over Ethernet, CAN, or USB interfaces. Commands are used to control movement, set configuration parameters, and control response data. Response messages provide detailed information about the current status of the RMP. Segway has chosen to allow users to control overall RMP movement, but not individual wheels/motors. This frees users to treat the RMP as a single unit rather than a collection of components, and allows Segway to provide a more robust, predictable mobility platform.



To allow for the greatest possible control over the RMP's behavior, a variety of configuration parameters can be modified. However, it is possible to set these parameters to unsafe values, so care must be taken when setting parameters to reduce the risk of damage or injury. It is the user's responsibility to set configuration parameters to safe values. Be sure to follow all safety instructions in this document.

This manual describes the capabilities of the RMP and explains how to communicate with it. Integrators and engineers can use this information to mount equipment on the RMP and write software for controlling the RMP.

Safety

Improper use of the RMP can cause personal injury, death and/or property damage from loss of control, collision, and falls. To reduce risk of injury, read and follow all instructions and warnings in this manual.

The following safety messaging conventions are used throughout this document:

 WARNING!	Warns you about actions that could result in death or serious injury.
 CAUTION!	Warns you about actions that could result in minor or moderate injury.
NOTICE	Indicates information considered important, but not related to personal injury. Examples include messages regarding possible damage to the RMP or other property, or usage tips.

WARNING!

- Keep out of reach of children and pets. Unanticipated movement by the RMP could result in death or serious injury.
- Do not sit, stand, or ride on the RMP. Doing so could result in death or serious injury.
- Do not drive the RMP at people or animals. A collision could result in death or serious injury.
- Always alert people in the vicinity when an RMP is operating. An unexpected collision with the RMP could result in death or serious injury.
- Avoid powering off on a slope. The RMP cannot hold its position when powered off and may roll downhill, causing serious injury, death, or property damage.
- The RMP can accelerate rapidly. It is recommended that the RMP be securely raised so the wheels are off the ground (or remove the wheels) until the user becomes familiar with the controls. Unanticipated movement by the RMP could result in death or serious injury.
- Be careful when working with the DC power connections. You could shock yourself and/or damage the RMP.
- Remove batteries before working inside the RMP. You risk serious bodily injury from electric shock as well as damage to the RMP.
- Do not submerge the RMP, batteries, or powerbases, in water. Do not use a power washer or high-pressure hose to clean a RMP. Avoid getting water into any of the connectors. If you suspect the batteries or powerbase have been submerged or experienced water intrusion, call Segway Technical Support immediately at 1-866-473-4929, prompt #2. Until you receive further instructions, store the RMP upright, outdoors, and away from flammable objects. Failure to do so could expose you to electric shock, injury, burns, or cause a fire.
- Unplug or disconnect the RMP from AC power before removing or installing batteries or performing any service. Never work on any part of the RMP when it is plugged into AC power. You risk serious bodily injury from electric shock as well as damage to the RMP.
- The cells within the batteries contain toxic substances. Do not attempt to open batteries. Do not insert any object into the batteries or use any device to pry at the battery casing. If you insert an object into any of the battery's ports or openings you could suffer electric shock, injury, burns, or cause a fire. Attempting to open the battery casing will damage the casing and could release toxic and harmful substances, and will render the battery unusable.
- As with all rechargeable batteries, do not charge near flammable materials. When charging, the batteries heat up and could ignite a fire.
- Do not use a battery if the battery casing is broken or if the battery emits an unusual odor, smoke, or excessive heat or leaks any substance. Avoid contact with any substance seeping from the battery. Batteries contain toxic and corrosive materials that could cause serious injury.
- Observe and follow all safety information on the warning label found on the battery. Failure to do so could result in death, serious injury, or property damage.
- Do not use cables that are frayed or damaged. You could shock yourself and/or damage the RMP.
- Use only Segway approved fasteners on the RMP. Other fasteners may not perform as expected and may come loose. Failure to do so could expose you to risk of personal injury or property damage.
- Use assistance when moving or lifting the RMP. Single person lifting could result in serious injury.

⚠ CAUTION!

- Be responsible about setting performance parameters. Read the relevant sections of this manual before changing any performance parameters. The RMP follows commands issued to it, and it is the responsibility of the user to properly safeguard their controls.
- Failure to charge the batteries could result in permanent damage to them. Left unplugged, the batteries could fully discharge over time, causing permanent damage.
- Use only charging devices approved by Segway and never attempt to bypass or override their charging protection circuits.
- Always protect against electrostatic discharge (ESD) when working inside the RMP. The RMP could become damaged.

NOTICE

- This equipment has been tested and found to comply with the limits for a Class B digital device, pursuant to Part 15 of the FCC Rules. These limits are designed to provide reasonable protection against harmful interference in a residential installation. This equipment generates, uses and can radiate radio frequency energy and, if not installed and used in accordance with the instructions, may cause harmful interference to radio communications. However, there is no guarantee that interference will not occur in a particular installation. If this equipment does cause harmful interference to radio or television reception, which can be determined by turning the equipment off and on, the user is encouraged to try to correct the interference by one or more of the following measures:
 - Reorient or relocate the receiving antenna.
 - Increase the separation between the equipment and receiver.
 - Connect the equipment into an output on a circuit different from that to which the receiver is connected.
 - Consult the dealer or an experienced radio/TV technician for help.
- This Class B digital apparatus complies with Canadian ICES-003.
Cet appareil numérique de la classe b est conforme à la norme NMB-003 du Canada.
- Modifications not expressly approved by Segway may void the user's authority to operate this device under FCC regulations and must not be made.

Abbreviations

ABB	Auxiliary Battery Board — a PCB used to gather and report performance information from the auxiliary battery.
BCU	Battery Control Unit — a PCB inside the battery pack that manages the charge of the individual cells.
BSA	Balance Sensor Assembly — a group of PCBs used to obtain information about the vehicle's orientation.
CAN	Controller Area Network — a message-based protocol used for communication between microcontrollers.
CCU	Centralized Control Unit — a PCB that houses the SP, UIP, and NVM; it controls the RMP and handles communication.
CRC	Cyclic Redundancy Check — a type of error-detection used to verify the accuracy of transmitted data.
DLC	Data Length Code — a part of the CAN message header that specifies the size of the data packet being sent.
DTZ	Decelerate To Zero — an operational mode in which the RMP comes to a stop and powers down.
LE	Large Enclosure — a unified chassis/enclosure for 4-wheeled RMP models.
MCU	Motor Control Unit — a PCB that controls the electric motors that turn the wheels.
NVM	Non-Volatile Memory — a type of digital memory that can retain the stored information even when not powered.
OCU	Operator Control Unit — software and hardware that provide an interface between the user and the RMP.
PCB	Printed Circuit Board — a thin board with conductive pathways and electronic components mounted on it.
PSE	Pitch State Estimate — a 3-axis inertial estimate of the orientation of the RMP.
RMP	Robotics Mobility Platform — a propulsion system that can be used as a platform for making mobile robots.
SCB	Smart Charger Board — a PCB that controls battery charging functions.
SE	Small Enclosure — a box that contains all of the electrical components of the RMP.
SID	Standard ID — a CAN identifier that indicates the type of message being sent.
SOC	State Of Charge — a measurement of battery charge from 0% (empty) to 100% (full).
SP	Segway Processor — a microcontroller on the CCU that contains proprietary Segway code for controlling the RMP.
SPI	Serial Peripheral Interface — a synchronous serial data link standard that operates in full duplex mode.
UDP	User Datagram Protocol — a simple, transaction-oriented network protocol on top of TCP/IP.
UDFB	User Defined Feedback Bitmap — a stored value that indicates what feedback data should be sent to the user.
UI	User Interface — the means by which an operator interacts with a device.
UIP	User Interface Processor — a microcontroller on the CCU that communicates with the OCU.
USB	Universal Serial Bus — an industry-standard bus for communication and power supply between computers and peripherals.
VAB	Vicor Adapter Board — a PCB that interfaces with Vicor DC-DC converters.

RMP 440 SE

The RMP 440 SE is a battery-powered Robotics Mobility Platform (RMP) meant to be used as the propulsion system for a robotic product. It has four 21-inch all-terrain tires and two powerbases mounted on side rails. Electrical components are mounted inside a User Interface (UI) box on the rear powerbase. Propulsion batteries are mounted to the bottom of the powerbases. The auxiliary battery is mounted to the top of the UI box.

The on/off switch, external connectors, and indicator lights are mounted on an interface panel at the rear of the machine. Communication with the RMP can occur over Ethernet, CAN, and USB.

Inside the UI box are the Centralized Control Unit (CCU), Auxiliary Battery Board (ABB), Smart Charger Board (SCB), and Power Converter(s). Cables run from the UI box to the powerbases.



Figure 1: RMP 440 SE

Included Components

The RMP 440 SE comes with a Disable Button, Starter Breakout Harness, and External Power Supply. The Disable Button must be connected for the RMP to enter Standby Mode. When pressed, the Disable Button will cause the RMP to immediately shut down. The Starter Breakout Harness provides Ethernet, CAN, and USB connectors as well as leads for DC power. The External Power Supply is used to charge the RMP. When connected, indicator lights on the UI box show the charge status of each battery.

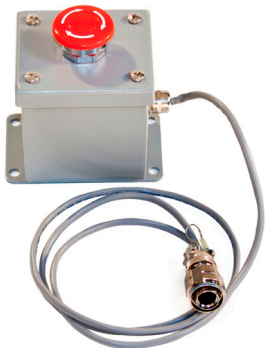

Figure 2: Disable Button



Figure 3: Starter Breakout Harness



Figure 4: External Power Supply

Capabilities

The RMP is meant to be used by integrators when creating mobile robotic products. As such, the RMP was designed with flexibility and expandability in mind.

Driving

The RMP can drive forward, reverse, and can turn in place¹. Turning is accomplished by skid steering — where the wheels actually skid across the ground as the RMP turns. A variety of parameters can be adjusted for easier driving in different circumstances, making it possible to have fine control at slow speeds and at high speeds. Adjustable parameters include maximum velocity, maximum acceleration, maximum deceleration, maximum turn rate, and maximum turn acceleration.

Velocity control can either be velocity-based (m/s) or acceleration-based (m/s²). With velocity-based control the user continually sends the desired velocity command (e.g. by holding a joystick steady to achieve a steady velocity). With acceleration-based control, acceleration commands are sent until the RMP reaches the desired speed. Then an acceleration of zero is commanded in order to maintain that speed. This is similar to using cruise control on the highway. See "Controller Input Mapping," p. 53, for more information on the different types of control.

For safety, a disable button is provided with the RMP. When pressed, the disable button will cause the RMP to shut down. A Decel To Zero (DTZ) command can also be sent, either by hardware button (not supplied) or by software command. This command causes the RMP to decelerate and come to a stop before powering down.

Payload

Users can mount equipment to the rails along the sides of the RMP. Mounting holes are provided along the tops of the rails and on the ends of the rails.

The maximum total payload is 180 kg (400 lbs), evenly distributed.

Communication

Communication with the RMP can occur over Ethernet, CAN, or USB. If using Ethernet the IP address, port number, subnet mask, and gateway can all be configured. For both Ethernet and USB communications, a Cyclic Redundancy Check (CRC) is performed, which verifies the accuracy of the transmitted data.

The RMP communicates via a polling method: the user sends a command and the RMP responds. Commands can be either motion commands (that tell the RMP to move) or configuration commands (that set user-configurable parameters). Some of these parameters — the User Defined Feedback Bitmaps — control what information is sent in the RMP response, allowing the user to receive only the relevant data.

The RMP expects to receive commands within a frequency range (0.5 Hz - 100 Hz). If commands are issued too frequently the RMP will ignore them. If commands are updated too slowly the RMP will slew the commands to zero.

Power

With an auxiliary battery, the RMP can provide power for additional equipment. The RMP 440 SE has space for two Power Converters. For more information see "Power Converter," p. 23.

Control Interface

The user is responsible for creating an interface for communicating with and controlling the RMP. Details on how to communicate with the RMP and interpret its responses are described later in this document (see "Communication," p. 36).

To make this process easier, Segway provides an OCU Demo Application and source code (see "OCU Demo Application," p. 92). This application is fully functional, but is not intended to be an end solution. Instead it is meant to be used as a functional example of how to interface with the RMP.

¹Turn radius is dependent upon the friction between the RMP tires and the ground. In some circumstances the RMP may not be able to turn in place.

Coordinate System

The Balance Sensor Assembly (BSA) uses accelerometers and gyroscopes to determine the position and movement of the RMP, all of which are used to create the Pitch State Estimate (PSE). This data is available to the user.

The RMP has a coordinate system relative to forward/reverse, pitch, roll, and yaw. This coordinate system is used when controlling the RMP. The diagrams below show the RMP's axes and coordinate system.

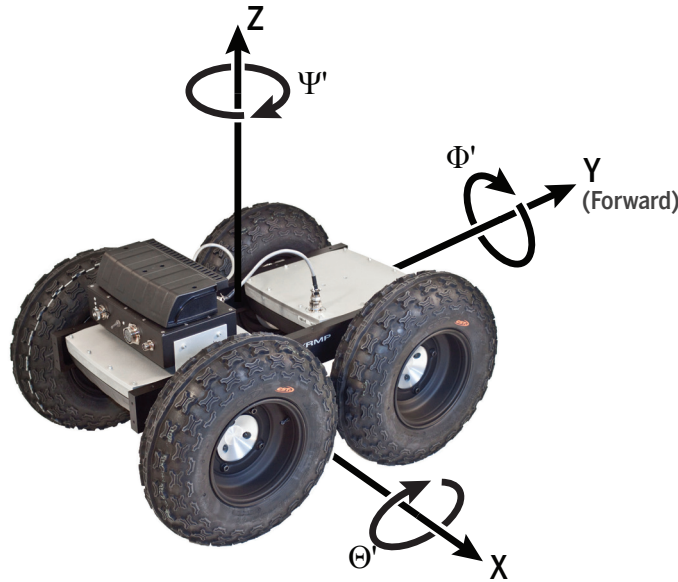

Figure 5: RMP 440 SE Axes

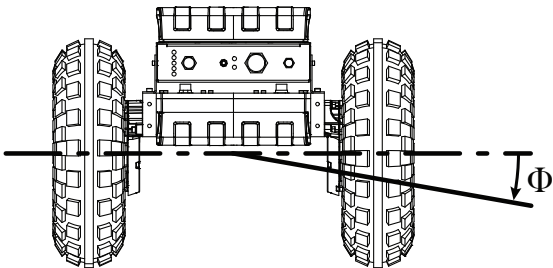

Figure 6: RMP 440 SE Roll Axis

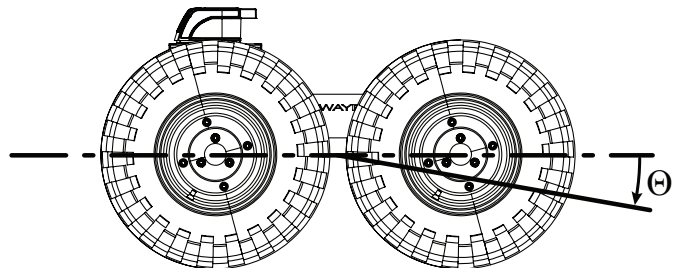

Figure 7: RMP 440 SE Pitch Axis

The variables listed below provide momentary information about the state of the RMP. For information on how to receive this data see "User Defined Feedback Bitmaps," p. 56.

Table 1: BSA and PSE Variables

UDFB Variable	Symbol	Measurement	Units
inertial_x_acc_g	X	Linear Acceleration	g
inertial_y_acc_g	Y	Linear Acceleration	g
inertial_x_rate_rps	X	Angular Velocity	rad/s
inertial_y_rate_rps	Y	Angular Velocity	rad/s
inertial_z_rate_rps	Z	Angular Velocity	rad/s
pse_pitch_deg	Θ	Angle (From Normal)	deg
pse_pitch_rate_dps	Θ'	Angular Velocity	deg/s
pse_roll_deg	Φ	Angle (From Normal)	deg
pse_roll_rate_dps	Φ'	Angular Velocity	deg/s
pse_yaw_rate_dps	Ψ'	Angular Velocity	deg/s

Physical Characteristics

For product dimensions, please refer to the diagrams below. A summary of the major dimensions is provided in Table 2.

Note: product options may change the characteristics of the RMP.

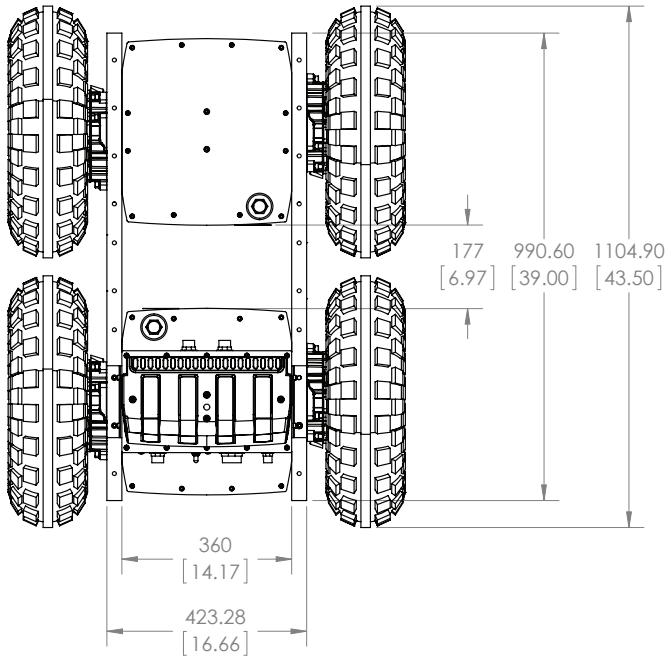

Figure 8: RMP 440 SE Top View

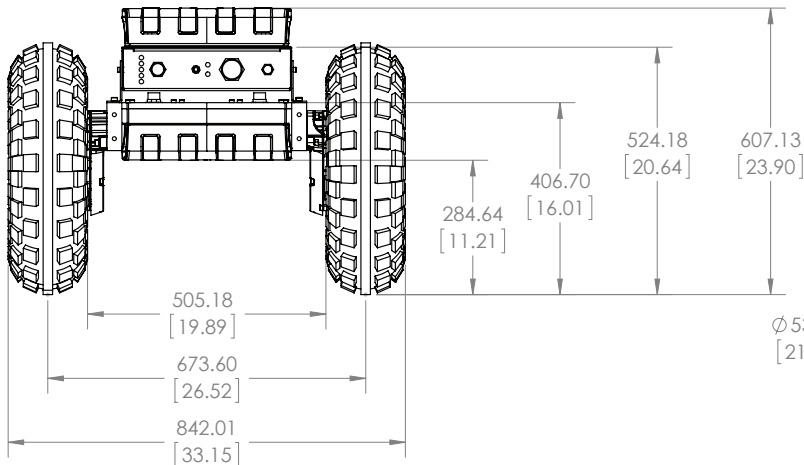

Figure 9: RMP 440 SE Back View

Table 2: Physical Characteristics

Characteristic	Value
Overall	
Length	1105 mm (43.5 in)
Width	842 mm (33.2 in)
Height	607 mm (23.9 in)
Chassis	
Length	991 mm (39.0 in)
Width	423 mm (16.6 in)
Height	322 mm (12.7 in)
Clearance	272 mm (10.7 in)
Tires	
Tire Size	AT21x7-10
Wheel Base	572 mm (22.5 in)
Track Width	674 mm (26.5 in)
Recommended Tire Pressure	6 psi
Other	
Weight	106 kg (235 lbs)

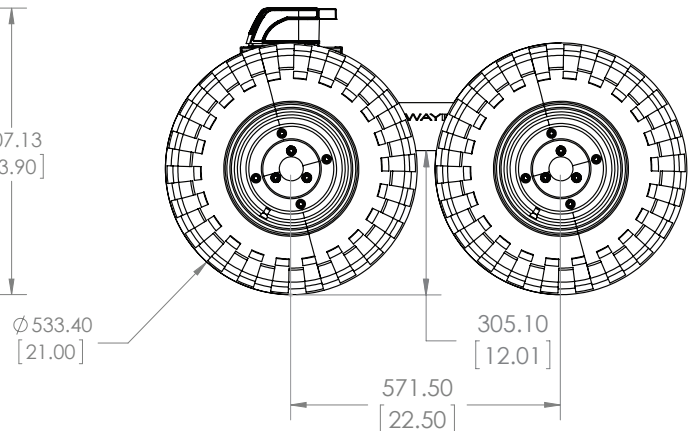

Figure 10: RMP 440 SE Side View

Mounting Locations

Equipment can be mounted to the RMP using the provided mounting locations. Tapped holes are located on the tops of the rails and on the ends of the rails. Tapped holes are M8x12. Dimensions are mm [in].

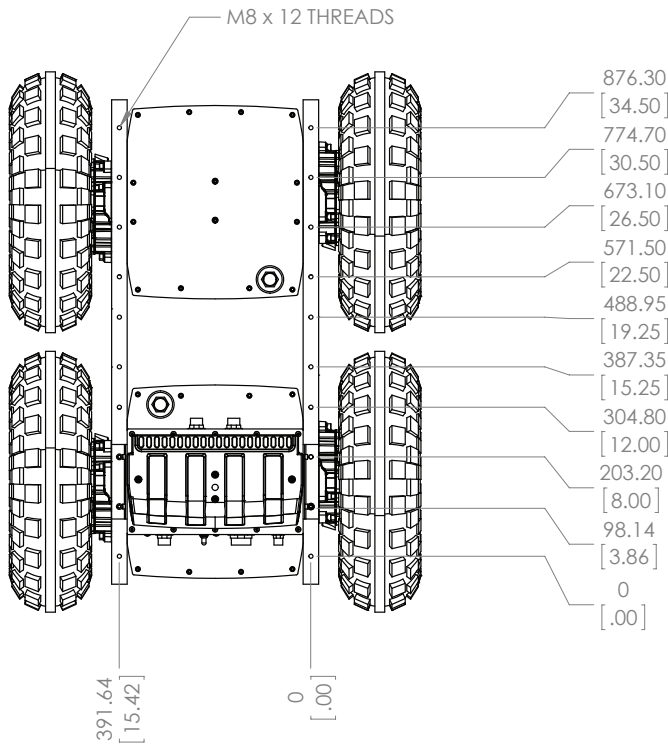

Figure 11: RMP 440 SE Top Mounting Holes

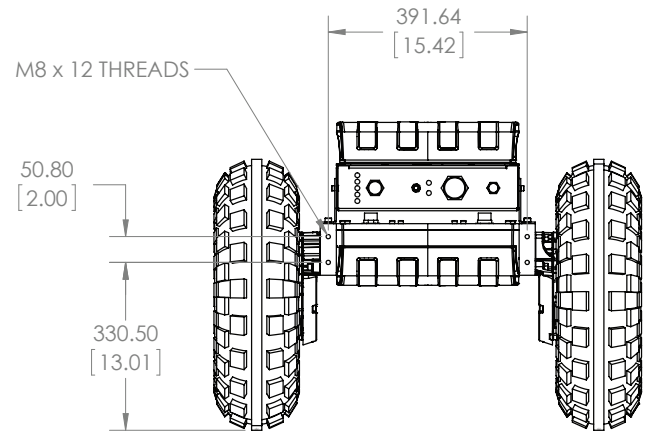

Figure 12: RMP 440 SE End Mounting Holes

NOTICE

Only mount equipment via the provided mounting locations. Drilling holes in the enclosure or other modifications to the RMP may adversely affect the FCC rating, IP rating, and/or structural integrity of the RMP.

User Interface Panel

The power switch, LEDs, and external connectors for the RMP are all located on the User Interface Panel on the rear of the RMP. Users should familiarize themselves with the various connectors and LEDs. For information on the connectors and what plugs into them see "Connecting," p. 30.

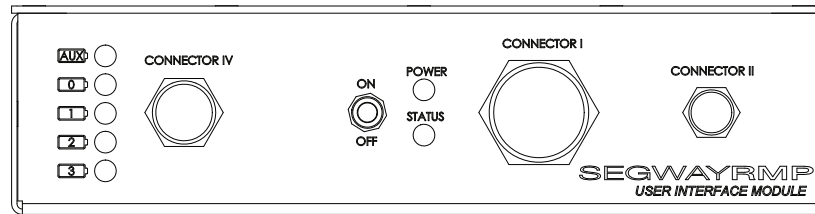

Figure 13: Interface Panel

ON/OFF Switch

Use this switch to power on and off the RMP.

Power and Status LEDs

These two LEDs indicate what mode the RMP is in. They can be used to troubleshoot startup issues. See "Powering On/Off," p. 29, for a list of what the LEDs indicate.

Connector I

This connector is used for communication and for auxiliary power. Communication available through this connector includes Ethernet, USB, and CAN. Auxiliary power available depends on the Power Converters installed. Up to two different DC voltages can be made available. The Starter Breakout Harness connects here.

Connector II

The Disable Button connects here. The Disable signal must be sent for normal operation. Other signals include: the Decel Request, used to initiate a Decel to Zero (DTZ); the Boot1 signal, used to enter Diagnostic mode; and the Boot2 signal, used to enter Bootloader mode.

Connector IV

This connector is used in conjunction with the External Power Supply for charging the batteries of the RMP. For more information on charging see "Charging," p. 28.

Charge Status LEDs

When charging the batteries, the Charge Status LEDs will light up, indicating the status of each of the batteries. Each LED corresponds to a specific battery. For more information see "Charging," p. 28.

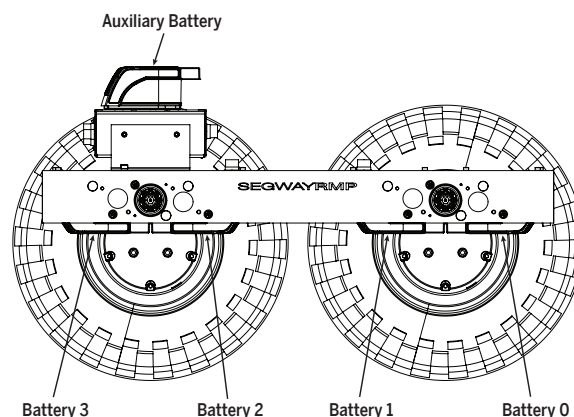

Figure 14: Battery Locations

Powerbase Connections

On the side of the enclosure there are two powerbase connectors. The left-hand connector goes to the front powerbase; the right-hand one goes to the rear powerbase. If there is only one powerbase, the left-hand connector is used. Powerbases must be plugged into the proper connectors for the charge status LEDs to be correct.

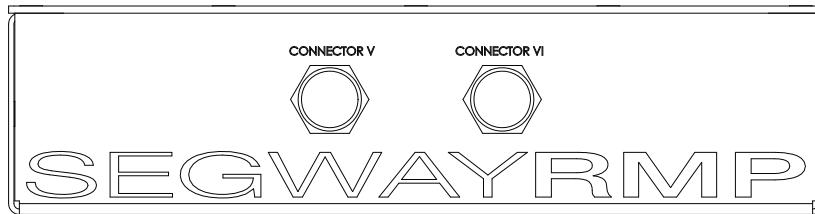

Figure 15: Powerbase Connections

Connector V

Connect the primary (front) powerbase to this jack.

Connector VI

Connect the secondary (rear) powerbase to this jack.

Performance Specifications

The RMP is driven by four independent and fully redundant brushless DC drive motors. It can operate both outdoors and indoors, although the tires may damage carpet and scuff flooring. Traversable terrain includes asphalt, sand, grass, rocks, and snow.

All measurements are based on a standard RMP 440 SE with 21-inch wheels.

Table 3: Performance Specifications

Characteristic	Value
Mobility	
Max. Speed	8.0 m/s (18 mph)
Turn Radius ¹	0 minimum
Turn Envelope ¹	1295.4 mm (51 in)
Max. Slope ²	30°
Peak Torque (Each Wheel)	100 N-m (74 lb-ft)
Wading Depth (Standard Gearbox)	248 mm (9.7 in)
Wading Depth (Inverted Gearbox)	406 mm (16.0 in)
Maximum Range ³	50 km (30 mi)
Power	
Run Time ⁴	Up to 24 hours
Charge Time	2-3 hours
Battery Chemistry	LiFePO ₄
Propulsion Battery Capacity	380 Wh each
Auxiliary Battery Capacity	380 Wh
Payload	
Max. Payload ⁵	180 kg (400 lbs) centered
All-Terrain Payload ⁶	90 kg (200 lbs) centered

¹ Turn-in-place capability and turning radius are dependent on the load conditions, operating surface type, tire friction, etc.

² Based on an unloaded platform.

³ Based on an unloaded platform with 6 psi tires travelling in a straight line on level pavement. Actual performance may vary.

⁴ Run time based on internal battery power. Extended run time is possible with charger connected.

⁵ Turn-in-place and tight radius turns are not possible when operating on high traction surfaces with payloads at or near the maximum.

⁶ The maximum payload that will allow the RMP to turn in place even on high traction surfaces.

Environmental Specifications

The Segway RMP was designed to withstand environmental conditions both indoors and outdoors.

Table 4: Environmental Specifications

Characteristic	Value
Operating Temp. Range	0°–50° C
Storage Temp. Range	-20°–50° C
Ingress Protection ⁷	Designed to meet IP66 / NEMA 4

⁷ Batteries must be installed in order for enclosure to be fully sealed.

Endurance

Platform endurance is determined by measuring battery draw while performing various maneuvers. The power used while performing a maneuver describes the power used by a single battery. Because all four propulsion batteries are used evenly, the runtime of a single battery can be used to approximate the runtime of the entire propulsion system.

In many cases the propulsion batteries will limit the runtime of the RMP. However, there are some scenarios in which the auxiliary battery will be the limiting factor. Such cases include stationary operation and situations in which additional equipment is using the auxiliary battery as a power source.

To calculate the energy used by a given maneuver, first determine the length of time the maneuver will be performed. Then multiply that time (in hours) by the Watts used while performing the maneuver. This will give you the Watt-hours used. Subtract those Watt-hours from the Watt-hours remaining in the battery. Maximum battery capacity is 380 Watt-hours.

Stationary Power Usage

When the RMP is maintaining a stationary position on level ground, the auxiliary battery is the limiting factor when calculating runtime. The internal RMP components use approximately 16 Watts, allowing the auxiliary battery to last nearly 24 hours. In contrast, the propulsion motors require only 7 Watts to maintain position on level ground, leaving 55% SOC left in the propulsion batteries after 24 hours. During actual use, the power used by the propulsion batteries may be greater, especially if maintaining position on a slope.

Straight Line Power Usage

The following empirical relationships can be used to provide a rough estimate of power usage when travelling in a straight line. These relationships are based on tests performed on dry, level pavement and represent best-case scenarios. Actual performance may vary.

Power draw for an unloaded platform:

$$W = 29.38 \times p^{-0.16} \times v^{1.137}$$

W = Power Draw (Watts)

p = Tire Pressure (psi)

v = Velocity (m/s)

Power draw for a platform with 400 lbs additional mass:

$$W = 96 \times p^{-0.5} \times v^{1.1}$$

W = Power Draw (Watts)

p = Tire Pressure (psi)

v = Velocity (m/s)

Turn-in-Place Power Usage

Due to the nature of scrub steering, the RMP uses considerable power when turning in place. The information provided here is based on tests performed on dry, level pavement with tire pressure at 6 psi and 12 psi. Tests were performed at 1 rad/s. Greater speeds caused the RMP to become unstable and are not recommended. Actual performance may vary.

Above 400 Watts the RMP cannot turn continuously. This is represented by the grey area in the graph below.

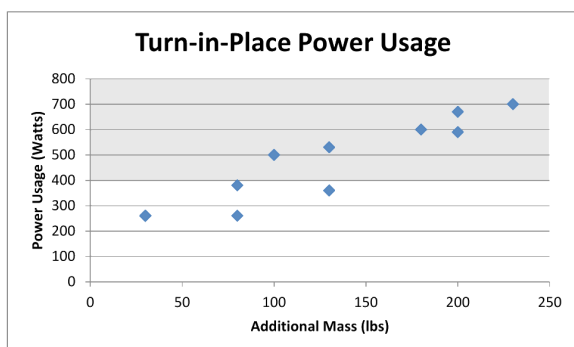

Figure 16: Turn-in-Place Power Usage

Turn-in-place power usage at 1 rad/s can be approximated using the following equation:

$$W = 2.24m + 181$$

W = Power Draw (Watts)

m = Additional Mass (lbs)

Endurance (cont.)

Turning Power Usage

When driving in circles or turning, power usage is based on the turning radius and the speed. The information provided here is based on tests performed on dry, level pavement with tire pressure at 6 psi and 12 psi. The smaller the radius, the more power is used. Actual performance may vary.

Figure 17 shows the power usage for an RMP with no additional mass. As mass increases, power usage also increases. The equations below can be used to estimate power usage for an unloaded platform and for a platform with 100 lbs additional mass.

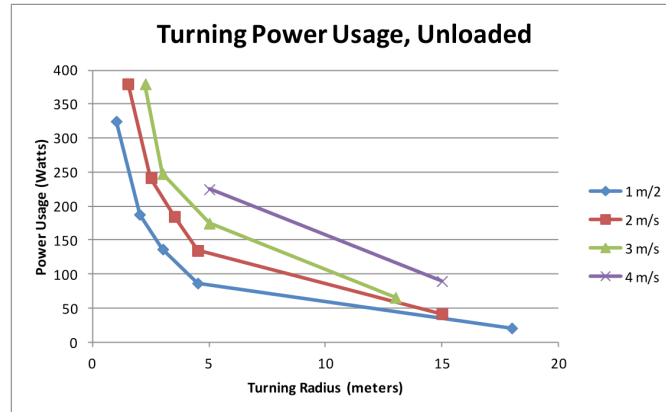

Figure 17: Turning Power Usage, Unloaded

The following empirical relationships can be used to approximate power usage when driving in circles.

Power draw for an unloaded platform:

$$W = (215v + 145)r^{-0.96}$$

W = Power Draw (Watts)

v = Velocity (m/s)

r = Radius (m)

Power draw for a platform with 100 lbs additional mass:

$$W = (410v + 364)r^{-1.04}$$

W = Power Draw (Watts)

v = Velocity (m/s)

r = Radius (m)

Transportation and Shipping

NOTICE

Lithium-ion batteries are regulated as "Hazardous Materials" by the U.S. Department of Transportation. For more information, contact the U.S. Department of Transportation at <http://www.phmsa.dot.gov/hazmat/regs> or call 1-800-467-4922.

To prevent damage to your RMP, always ship it in the original crate it came in. The crate disassembles for storage. If you do not have the original crate, contact Segway for a replacement (see "Contact Information," p. 5).

Electrical Overview

This section describes the components of the RMP and shows how they interact.

System Architecture

The RMP combines the robustness of the Segway powerbase with a versatile Centralized Control Unit (CCU). The powerbase is the same proven technology used in the Segway Personal Transporter (Segway PT). It controls the wheels, senses the RMP's orientation, and provides a mounting location for the batteries. The Centralized Control Unit coordinates the RMP's movement and controls communication among all the components. It acts as the interface between the RMP and the outside world. The diagram below shows how these components communicate with each other.

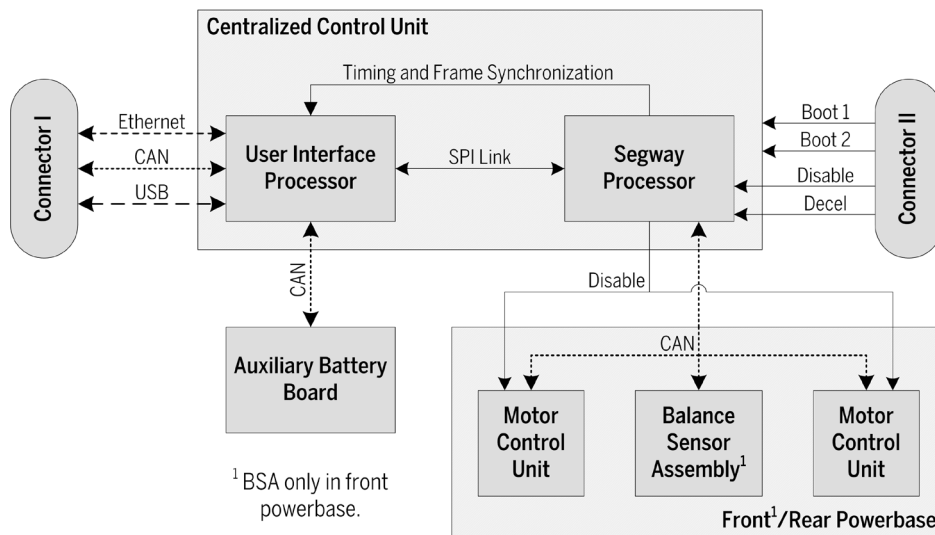

Figure 18: System Architecture Diagram

System Power

The RMP runs on rechargeable batteries. Power is routed from the batteries to the various components of the system. DC power is available for customer use.

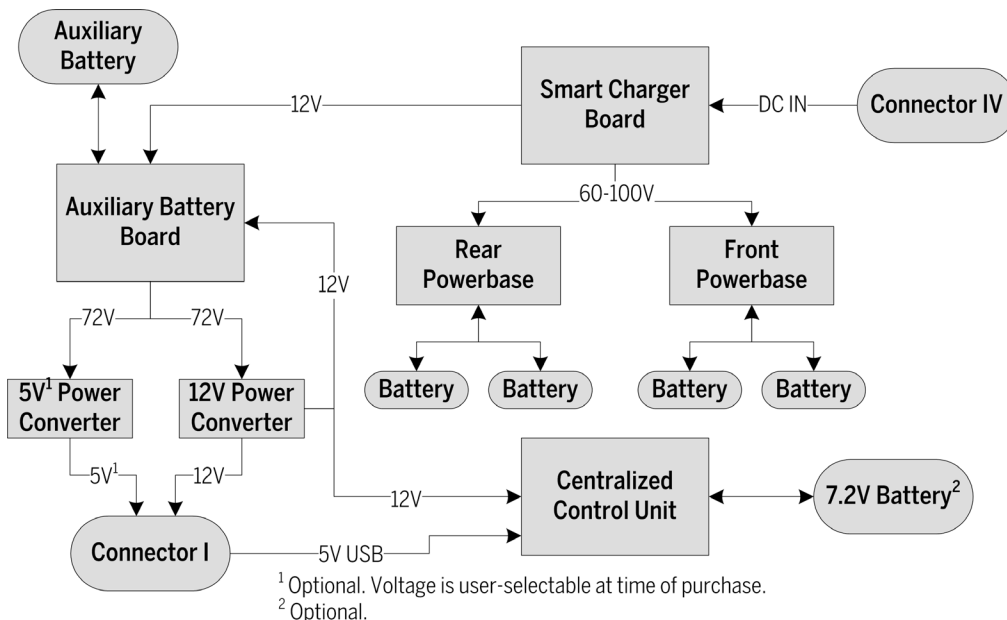

Figure 19: System Power Diagram

System Components

A brief overview of each component is provided to help you become familiar with these components and their functions.

Centralized Control Unit

The Centralized Control Unit (CCU) contains the Segway Processor (SP) and the User Interface Processor (UIP). These processors use synchronized timing to control the RMP in real time. They communicate via a Serial Peripheral Interface (SPI) link.

Segway Processor

The SP controls essential system functions including timing management, control algorithms, safety kernel functions, redundancy management, estimation algorithms, and Segway hardware interfaces. In addition, a real time clock and Non-Volatile Memory (NVM) allow for diagnostic fault logging.

User Interface Processor

The UIP controls the interaction between the user and the RMP. It allows the user to command RMP motion, configure machine parameters, and access faultlog information.

The UIP consists of four layers: System layer, I/O layer, Toolkit layer, and Application layer.

1. The System layer manages hardware-specific functionality like interrupts and timing.
2. The I/O layer manages all processor I/O including GPIO, ADC, DAC, CCP, USB, UDP, CAN, RS232, TTL Serial, and the SPI link. The I/O layer is responsible for gathering all raw UIP data and presenting it to the Toolkit layer.
3. The Toolkit layer abstracts the information gathered by the I/O layer and interprets it into meaningful system level data. The Toolkit layer then relays that information to various interfaces for consumption by the user.
4. The Application layer consists of an application stump for future expansion and development of the system.

Powerbase

The powerbase is one of the main components of the Segway PT and has been leveraged for use as the propulsion unit of the RMP. Each RMP 440 SE has two powerbases, one for the front wheels and one for the rear wheels. Inside each powerbase are two Motor Control Units (MCUs). Only the front powerbase contains a BSA. The powerbase is not serviceable by the user; this information is provided for completeness only.

Motor Control Unit

The MCU is a Segway motor drive. It utilizes the robustness of the Segway PT propulsion system as a motor drive. Each MCU has two motor drives that drive half of a dual hemisphere Segway motor. Each MCU performs its own internal fault detection and communicates with the SP via CAN interface. The user does not have access to the MCU interface.

Balance Sensor Assembly

The BSA provides redundant raw three-axis inertial data to the SP. The SP uses this information to compute the Pitch State Estimate (PSE). The PSE algorithm estimates the machine orientation and movement based on the combined raw inertial information and wheel odometry.

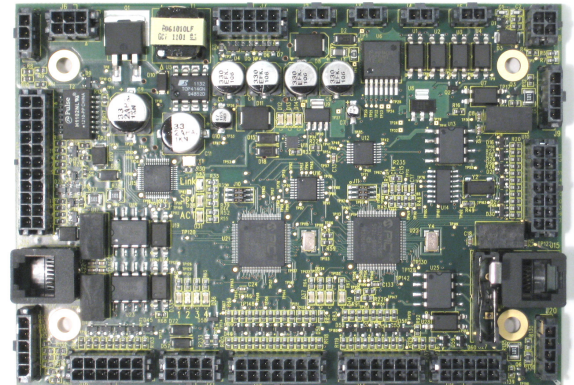

Figure 20: Centralized Control Unit

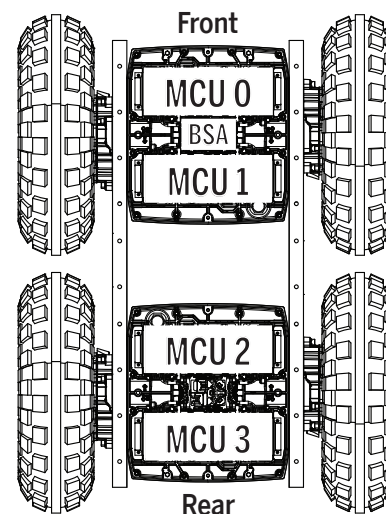

Figure 21: Segway Powerbases

Smart Charger Board

The Smart Charger Board (SCB) distributes charging current from the External Power Supply to the ABB and both powerbases. It controls multiple high current smart chargers and manages charging. It has 5 monitored channels at 100 VDC each and can perform fault detection down to the level of the power supply, board, and battery.

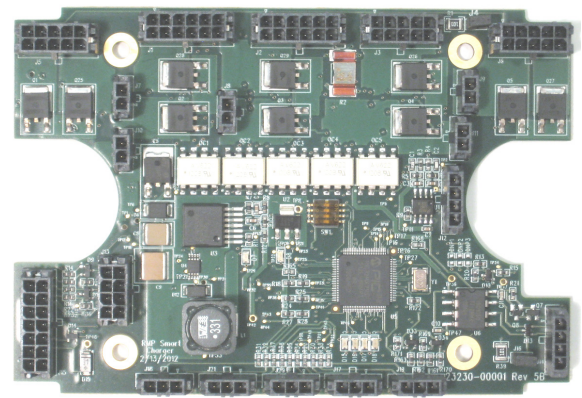

Figure 22: Smart Charger Board

Auxiliary Battery Board

The Auxiliary Battery Board (ABB) monitors voltage, current, state of charge, and battery flags of the auxiliary battery pack. It has software protected outputs to prevent over-discharge of the battery. The board can act as a standalone unit or can connect to the CCU. It interfaces with the UIP via CAN and provides real-time battery data and status information for the auxiliary battery pack. The ABB can communicate via CAN, USB, and RS232.

If the fuse blows, the entire board must be replaced.

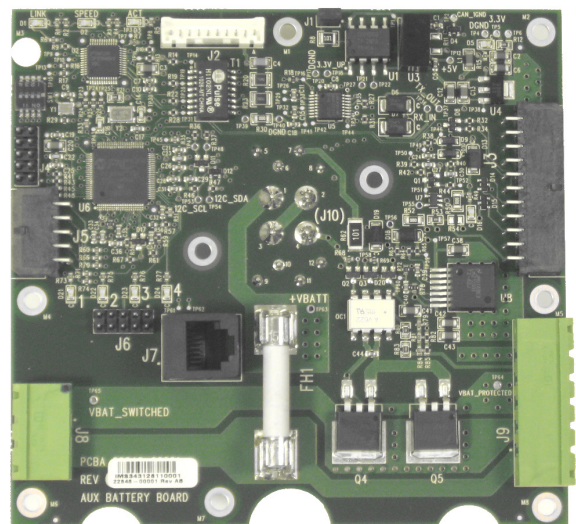

Figure 23: Auxiliary Battery Board

Power Converter

The RMP 440 SE accommodates up to two Power Converters. Each Power Converter accepts 72 VDC input power and provides DC output power at a different voltage. One Power Converter provides 12 VDC power for internal use and customer use. The other Power Converter is selectable at time of purchase. Output voltage options include 5 VDC, 12 VDC, 24 VDC, 36 VDC, and 48 VDC.

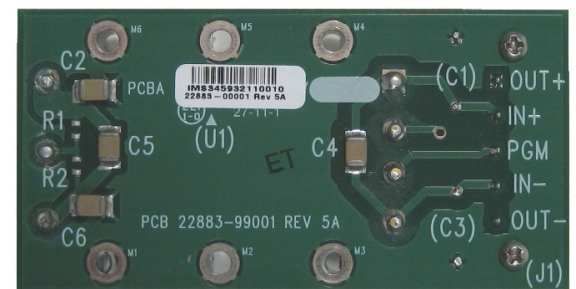

Figure 24: Power Converter

Operational Model

This chapter describes powering on, powering off, and the various modes of operation.

Operational States

At any given time, the RMP will be in one of the following operational states:

- Initialization
- Diagnostic Mode
- Bootloader Mode
- Standby Mode
- Tractor Mode
- Disable Mode
- Off

Figure 25 shows how these states interact. Each of these states is discussed in more depth on the following pages.

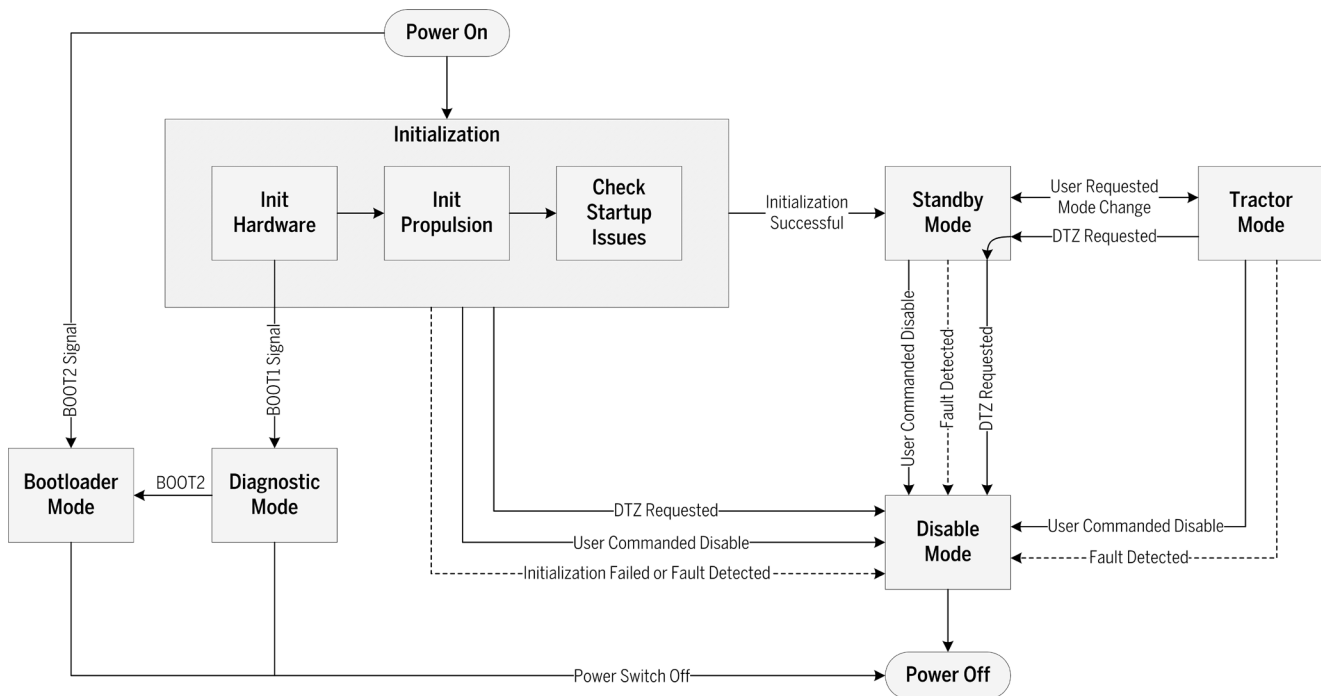

Figure 25: System State Diagram

Faults

Faults occur in response to events that impact the RMP. This could include anything from receiving a user-commanded DTZ signal to detecting a failed battery. Sometimes faults are the result of a problem that needs to be resolved. Other times they are merely informative.

In response to a fault the RMP may simply log the fault or it may take an action. There are four types of fault responses:

- No fault response — fault is logged. No change in RMP behavior.
- DTZ response — fault initiates a Decel To Zero. RMP comes to a stop, logs the fault, and powers off.
- Disable response — fault causes RMP to power off. RMP logs the fault and powers off immediately.
- Disable MCU response — fault causes a single MCU to go down. RMP will continue to operate unless the other MCU in the powerbase goes down as well.

Initialization

Initialization is composed of three sub-states: Init Hardware, Init Propulsion, and Check Startup Issues. First, the hardware is initialized; this includes the CCU and ABB. Then, propulsion is initialized (the MCUs and BSA). If there are no issues with the system, the RMP transitions to Standby Mode. Otherwise it shuts down.

If the BOOT1 or BOOT2 signal is pulled low the RMP will enter Diagnostic Mode or Bootloader Mode, respectively.

Init Hardware

During Init Hardware, the following steps are performed:

1. UIP and SP initialize hardware, interrupts, and software.
2. UIP and SP synchronize their timing.
3. UIP-SP communication is established.
4. SP reads configuration parameters from NVM, initializes dependent data, and passes the parameters to the UIP for UIP dependent data initialization.
5. UIP and SP verify configuration validity.
6. SP extracts the faultlog from NVM and relays the faultlog array to the UIP for user access.

Init Propulsion

During Init Propulsion the SP initializes each MCU using a state machine. Each state verifies a certain MCU operational status. If any MCU is not operating as expected, the RMP will transition to Disable Mode and power off. Information regarding the failure is stored in the faultlog

Check Startup Issues

In this sub-state the SP checks for various parameters that will gate entry to Standby Mode. When the RMP detects an issue, Standby Mode entry is gated and the RMP will emit a tone and blink the LEDs for five seconds before failing initialization. If the issue is corrected in this time, the transition to Standby Mode will be allowed.

The following issues will gate transition to Standby Mode:

- An MCU declares a fault.
- The RMP is charging (this can be overridden: see "RMP_CMD_SET_INPUT_CONFIG_BITMAP," p. 46).
- An MCU battery open circuit voltage is below the operational threshold.
- An MCU battery state of charge is below the operational threshold.
- 7.2 VDC battery (if present) has low or high voltage.
- Any detected machine motion (RMP moving un-commanded).
- Tractor mode request is present from the user.
- BSA communication has not been established.

Diagnostic Mode

In Diagnostic Mode the RMP stays in the Init System state without transitioning to Standby Mode. In this mode the RMP has initialized the CCU and ABB, but has not initialized propulsion. The user can communicate with the RMP but cannot command it to move. This mode allows the user to update configuration parameters and extract the faultlog without fully initializing the RMP; this is useful when a fault causes the RMP to shutdown before entering Standby Mode.

In this state the RMP will remain on as long as power is available.

To enter Diagnostic Mode:

1. Turn the RMP off.
2. Connect pins D and E on the 6-pin connector (for the full pinout, see "Connector II," p. 32).
3. Use the USB cable to connect the RMP to the computer. The RMP will power on.

This will pull the BOOT1 signal low. The RMP will begin initialization but will stop at Init System and remain there.

Bootloader Mode

In Bootloader Mode, the RMP remains in the bootloader stage without continuing on to the RMP applications. The user can then load new applications into either of the processors using the Bootloader Application (see "RMP CCU Bootloader Application," p. 91).

In this state the RMP will stay powered as long as USB power is available.

To enter Bootloader Mode:

1. Turn the RMP off.
2. Connect pins D and F on the 6-pin connector (for the full pinout, see "Connector II," p. 32).
3. Use the USB cable to connect the RMP to the computer. The RMP will power on.

This will pull the BOOT2 signal low. The RMP will stop at the bootloader stage without loading any applications or beginning initialization.

Standby Mode

In Standby Mode the RMP is fully functional with the exception that motion commands are not executed. The MCUs are enabled, the controllers are initialized, and the RMP is holding its position. Any motion commands issued will not be executed by the platform.

Standby mode is entered automatically after successful initialization. From here the user can initiate a transition to tractor mode or disable the RMP.

Tractor Mode

In Tractor Mode the RMP will accept motion commands from the user. This is the only mode in which the RMP can be commanded to move. In this state the MCUs are enabled and the controllers are running. Motion commands issued by the user will be accepted.

Tractor Mode can only be entered from Standby Mode as the result of a user mode request (see "RMP_CMD_SET_OPERATIONAL_MODE," p. 50). From here the user can initiate a transition back to Standby Mode or can disable the RMP.

Disable Mode

WARNING!

When the RMP powers off it may continue to move (for example, it could roll downhill). This could cause personal injury and property damage.

In Disable Mode the RMP performs housekeeping functions and then powers off. In this mode the propulsion drives are disabled and all user commands are ignored.

In this mode the following actions are performed:

1. Drives are disabled via software and hardware.
2. The ABB shuts down the protected +72 V output.
3. The processors go into reset.
4. The RMP powers off.

If the RMP is powered off via the on/off switch, none of the above housekeeping functions are performed. The recommended way to power off the RMP is to send a powerdown request (see "RMP_CMD_SET_OPERATIONAL_MODE," p. 50, and "Powering Off," p. 29).

Disable Mode can be entered at any time via user command (see "General Command Structure," p. 37). Some faults will also cause a transition to Disable Mode.

Charging

⚠ WARNING!

Do not plug in the charger if the charge port, power cord, or AC power outlet is wet. You risk serious bodily injury or death from electric shock as well as damage to the RMP.

⚠ CAUTION!

Failure to charge the batteries could result in damage to the batteries. Left unplugged, the batteries could fully discharge over time, causing permanent damage. Use only charging devices approved by Segway.

The RMP 440 SE requires the External Power Supply to charge the batteries. This power supply converts AC power to DC power for use by the RMP. The Smart Charger Board inside the RMP distributes this power as needed to the batteries for charging.

Charging requires that the temperature be within 0° C – 50° C and the humidity be <90%, non-condensing.

Using the External Power Supply

An External Power Supply is supplied with the RMP 440 SE.

The charge port (Connector IV) is located on the interface panel next to the Charger Status LEDs.

1. Connect the External Power Supply to the charge port on the RMP (Connector IV).
2. Plug the External Power Supply into a standard AC wall outlet.
3. Turn on the External Power Supply by toggling the switch.

Charge Status LEDs

There is one LED for each 72 V Segway battery attached to the RMP. When charging, the LEDs turn green. If a battery is at maximum charge, its LED blinks. See Table 6 for a complete list of what the LEDs indicate.

NOTICE

If the RMP is already charging and the RMP is powered on, the RMP will error and turn itself off. This is to prevent users from turning on the RMP and driving it away while it is still plugged in. This functionality can be changed by disabling the AC Present CSI in the Input Config Bitmap (see "RMP_CMD_SET_INPUT_CONFIG_BITMAP," p. 46).

Table 6: Battery LEDs

LED Status	Meaning
Off	Battery is not charging.
Green	Battery is charging.
Green Blinking	Battery in balance mode. The time between blinks gets longer as the cells come into balance.
Red	Fault or battery not present.
Red Blinking	Charging fault. See "Charging Faults," p. 109.

Table 5: External Power Supply Input/Output

Characteristic	Value
Input Voltage	100-250 VAC 50/60 Hz
Max. Input Current	2.4 A @ 100 VAC per channel
Output Voltage	57-95 VDC
Output Current	2.1 A per channel

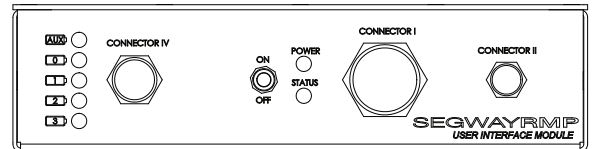

Figure 26: RMP 440 SE Interface Panel



Figure 27: External Power Supply, Front



Figure 28: External Power Supply, Back

Powering On/Off

This section describes how to turn the RMP on and off.

Powering On

The RMP can be turned on and off using the toggle switch mounted on the interface panel. Plugging in the USB connector will also power on the RMP.

When successfully powered on, the RMP enters Standby mode, which is indicated by a blinking yellow LED and a solid green LED.

1. Make sure the disable button is connected and has not been pressed.
2. Flip the toggle switch to ON or connect via USB.
3. Wait for the RMP to enter Standby mode.

NOTICE

- Auxiliary power will not be available unless the toggle switch is ON.
- If the red LED blinks rapidly and then turns off, double-check the disable button (see "Troubleshooting," p. 103). If powered from USB, try disconnecting USB cable and toggling on/off switch ON.

Table 7 shows the various operational modes and LED indicator patterns.

Table 7: Indicator LEDs

Mode	Power LED	Status LED
System Initialization	Yellow Blinking	Off
Standby Mode	Yellow Blinking	Green Solid
Tractor Mode	Yellow Blinking	Green Blinking
Bootloader Mode	Yellow/Red Toggling	Off
Diagnostic Mode	Red Blinking, Sync'd	Green Blinking, Sync'd
Reset Processors	Red Blinking Rapid	Off
Disable Power	Red Solid	Off

Powering Off

There are a few ways that the RMP can be powered off. Each is described in Table 8 below.

⚠ WARNING!

When the RMP powers off it may continue to move (for example, it could roll downhill). This could cause personal injury and/or property damage.

Table 8: Power Down Methods

Method	Resulting Behavior
User commanded Power Down	The RMP powers down normally, performing housekeeping tasks. No fault is logged.
User commanded Disable	The RMP logs the disable request as a fault and powers down.
User commanded Decel To Zero (DTZ)	The RMP comes to a stop, logs the DTZ request as a fault, and powers down.
On/Off switch is set to off	Power is immediately removed from the system. No housekeeping tasks are performed. The RMP immediately shuts down.
Disable button is pressed	The RMP logs the disable button press as a fault and powers down.
Hardware DTZ input	The RMP comes to a stop, logs the DTZ Input as a fault, and powers down.

NOTICE

A fault response may also result in the machine powering off.

Connecting

This chapter describes how to connect to the RMP. Included are the pinouts for all the panel connectors as well as detailed descriptions of the Starter Breakout Harness and the Disable Button.

Connector I

Connector I is the largest external connector on the RMP. This approximately 2-inch diameter connector is a MIL-DTL-38999/24FJ4SN connector with 56 pins. It houses all the communication interfaces to the platform and provides power available for customer loads.

Communication interfaces passing through this connector are Ethernet, USB, and CAN. Power available is dependent upon which Power Converters have been selected. Power is only available when the auxiliary battery option is included.

This is a MIL-DTL-38999/24FJ4SN socket. Mating connector is a MIL-DTL-38999/26FJ4PN plug.

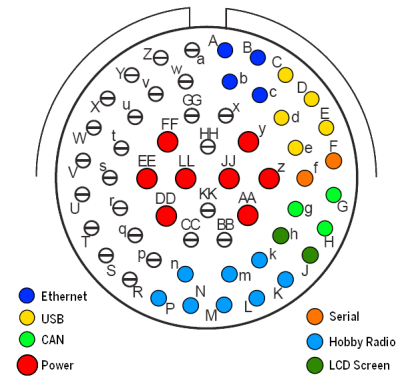

Figure 29: 56-Pin Connector

Table 9: Connector I Pinout

Pin	Signal
A	ETHERNET TX+
b	ETHERNET TX-
B	ETHERNET RX+
c	ETHERNET RX-
C	USB_VBUS
D	USB_D+
d	USB_D-
E	USB_ID
e	USB_GND
F	SERIAL_TX ¹
f	SERIAL_RX ¹
G	CAN1H
g	CAN1L
H	CAN1_GND
k	RADIO1
L	RADIO2

Pin	Signal
m	RADIO3
M	RADIO4
N	RADIO5
n	RADIO6
P	RADIO_GND
K	RADIO+5V
J	LCD_POWER+5V
h	SERIAL_GND
y	POWER_1+
z	POWER_1-
AA	POWER_2+
JJ	POWER_2+
DD	POWER_2-
LL	POWER_2-
FF	POWER_3+
EE	POWER_3-

¹Not fully supported at time of printing.

Starter Breakout Harness

The RMP is supplied with a breakout harness that connects to the 56-pin connector. This harness screws onto Connector I and provides all the connections necessary to communicate with the RMP. It provides Ethernet, USB Type A, and CAN plugs as well as leads for power. The connector is fully mated when the red stripe on Connector I is no longer visible.

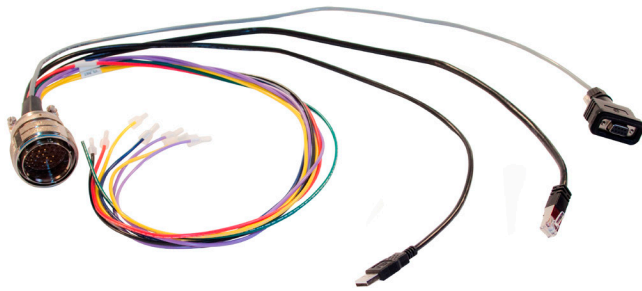

Figure 30: Starter Breakout Harness

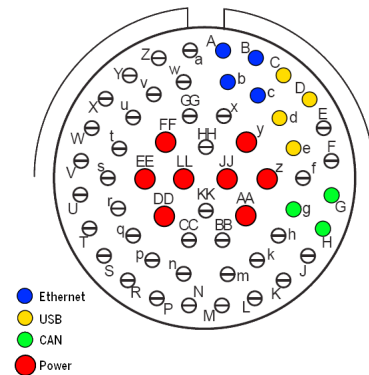

Figure 31: Starter Breakout Harness Pins

Ethernet

10 Mbps Ethernet is available on the 56-pin connector (see pinout, Table 10). The starter breakout harness includes a male RJ45 Ethernet plug.



Figure 32: RJ45 Plug

Table 10: Ethernet Pinout

RJ45 Pin	Signal	Connector I Pin
1	Ethernet TX+	A
2	Ethernet TX-	b
3	Ethernet RX+	B
6	Ethernet RX-	c

USB

USB 2.0 compliant interface is available on the 56-pin connector (see pinout, Table 11). The starter breakout harness includes a male USB Type A plug.



Figure 33: USB Plug

Table 11: USB Pinout

USB Pin	Signal	Connector I Pin
1	USB_VBUS	C
3	USB_D+	D
2	USB_D-	d
4	USB_GND	e
Housing	Chassis Ground	Housing

CAN

Controller Area Network connection is available on the 56-pin connector (see pinout, Table 12). The starter breakout harness includes a male DB9 connector for CAN communication.



Figure 34: Male DB9 Connector

Table 12: CAN Pinout

DB9 Pin	Signal	Connector I Pin
7	CAN1H	G
2	CAN1L	g
3	CAN1_GND	H

Power

The auxiliary battery feeds Power Converters (number of converters varies from depending on RMP model). At time of purchase, the customer has the option to select the output voltage of the Power Converters. Possible options are: 5 VDC, 12 VDC, 24 VDC, 36 VDC, and 48 VDC. One of the options selected must be 12 VDC, in order to power the CCU.

Specifics about the regulation, available current, and available power can be found by reviewing the datasheet for the 72 V micro family DC/DC regulators from Vicor (http://cdn.vicorpower.com/documents/datasheets/ds_72vin-micro-family.pdf).

Available DC voltages:

- 5 V
- 12 V
- 24 V
- 36 V
- 48 V

There are multiple slots for Power Converters. One slot must be 12 VDC; all others may be chosen from the above options at time of purchase.

Table 13: Power Pinout (16 AWG Contacts)

Wire Color	Voltage	Connector I Pin
Red	Power1+	y
Green	Power1- (Return)	z
Purple	Power2+	AA
	Power2+	JJ
Yellow	Power2- (Return)	DD
	Power2- (Return)	LL
Blue	Power3+	FF
Black	Power3- (Return)	EE

Connector II

This panel connector provides pins for the disable button, the DTZ (Decelerate To Zero) signal, and for entering Bootloader mode and Diagnostic mode. During normal operation, the #DISABLE_5V signal must be pulled up to +5 V, which is what the provided Disable Button achieves. Otherwise the RMP will fail the startup check and fault. For more information on these signals see "Operational Model," p. 24, and "Hardware Controls," p. 87.

This is a MIL-DTL-38999/24FB98SN socket. Mating connector is a MIL-DTL-38999/24FB98PN plug.



Figure 35: 6-Pin Connector

Table 14: Connector II Pinout

Signal	Pin
+5 V	A
DECEL_REQUEST	B
#DISABLE_5V	C
DGND	D
BOOT1	E
BOOT2	F
Chassis Ground	Housing

Disable Button

The Disable Button is a normally-closed pushbutton that attaches to Connector II. When the RMP boots up, it checks if the #DISABLE_5V signal has been pulled up to +5 V. The Disable Button achieves this by connecting pins A and C. If the #DISABLE_5V signal is not pulled up to 5 V (e.g. the Disable Button is absent or has been pressed), the RMP immediately powers down.

Additional Signals

The connector can also be used with a custom harness to send Decel requests as well as Boot1 and Boot2 signals. Boot1 is used for entering diagnostic mode. Boot2 is used for entering bootloader mode. For more information see "Operational Model," p. 24, and "Hardware Controls," p. 87.



Figure 36: Disable Button

Connector IV

This connector is used in conjunction with the External Power Supply. Charging is accomplished by connecting the External Power Supply to the RMP and then plugging the External Power Supply into a standard AC outlet. The pinout for this connector is provided for completeness.

For more information on charging see "Using the External Power Supply," p. 28.

This is a MIL-DTL-38999/24FD19PA plug. Mating connector is a MIL-DTL-38999/26FD19SA socket.

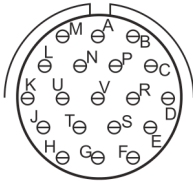

Figure 37: 19-Pin Connector

Table 15: Connector IV Pinout

Signal	Pin
DC+1	B
GND1	P
DC+2	M
GND2	N
DC+3	J
GND3	U
DC+4	G
GND4	T
DC+5	E
GND5	R
Not Connected	A, C, D, F, H, K, L, S, V

Connecting To the RMP

There are three interfaces for connecting to the RMP broken out on the Starter Breakout Harness:

- Ethernet
- CAN
- USB

All three methods provide the same functionality in regards to controlling the RMP and receiving feedback messages from the RMP.

NOTICE

Actual connection procedures may vary depending on which operating system is used. If you have any installation issues, please contact RMP support (see "Reporting Problems to Segway," p. 103).

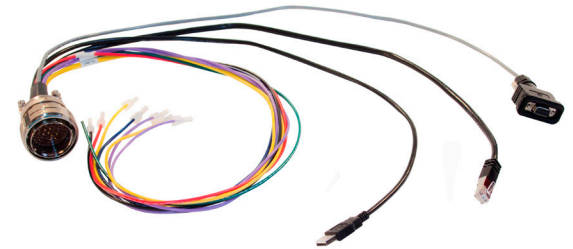

Figure 38: Starter Breakout Harness

Ethernet

The RMP has a 10 Mbps Ethernet connection. It uses a static Ethernet address that can be changed by modifying user-configurable parameters (see "Configuration Commands," p. 42).

When connecting to a router, configure the RMP like any other device with a static IP address.

When connecting directly to a computer:

- Computer IP address and RMP base address must match, but computer and RMP must have unique addresses.
- Computer subnet and RMP subnet must match.
- Computer gateway and RMP gateway must match.

See Table 17 for recommended computer settings.

The RMP uses UDP port 8080 to communicate over the Ethernet connection. The port number is user-configurable (see "RMP_CMD_SET_ETH_PORT_NUMBER," p. 47). The RMP sends and receives data on that port, so a connected computer must send and receive data on the same port as the RMP.

The RMP will only connect to one host computer at a time. A 30-second communication timeout is required when changing hosts.

The RMP will respond to ICMP ping requests.

Table 16: Default RMP Ethernet Settings

Parameter	Default Value
IP Address	192.168.0.40
Port	8080
Subnet Mask	255.255.255.0
Gateway	192.168.0.1

Table 17: Recommended Computer Settings

Parameter	Default Value
IP Address	192.168.0.100
Subnet Mask	255.255.255.0
Gateway	192.168.0.1

CAN

The RMP can communicate with any CAN-enabled device.

However, the included demo applications require a Kvaser USB-to-CAN adapter to be used. Other brands of USB-to-CAN adapters will not work with the demo applications.

To install a Kvaser adapter:

1. Download the Kvaser drivers from <http://www.kvaser.com/en/downloads.html>. As of the current printing the drivers for all of Kvaser's products are available in a single install file.
2. Install the Kvaser drivers. For details on how to install the drivers, see the Kvaser installation guide for your product.
3. Plug in your Kvaser device. The USB connector plugs into a USB port on your computer. The DB9 connector attaches to one of the leads on the RMP.
4. The "Found New Hardware Wizard" will appear.
5. Choose "Install software automatically" and click "Next."
6. Click "Finish" to close the wizard. The Kvaser USB-to-CAN connector is now installed.



Figure 39: Kvaser USB-to-CAN Adapter

NOTICE

Kvaser installs a new icon in the Control Panel.

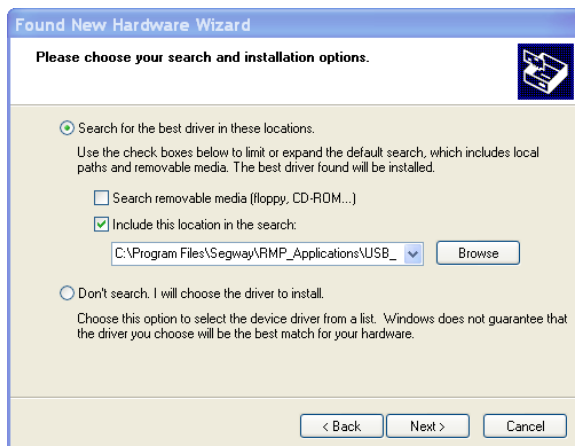

Figure 40: Select the USB_Drivers Folder

USB

USB drivers are included with the RMP software (see "Included Software," p. 90). These are custom Segway drivers and will not install automatically. When the "Found New Hardware Wizard" appears, the folder containing the drivers must be explicitly selected.

1. Connect a USB cable from the RMP to your computer.
2. The "Found New Hardware Wizard" will appear.
3. Select "Install from a list or specific location" and click "Next".
4. Point the installer to the USB Drivers folder (default location is C:\Program Files\Segway\RMP_Applications\USB_Drivers).
5. The install process will begin.
6. When the Windows Logo warning pops up, click "Continue Anyway".
7. Click "Finish" to close the wizard.

NOTICE

Generally the RMP uses a USB driver that allows it to operate as a CDC device with an RS232 emulator. However, in Bootloader mode the RMP uses a USB HID device driver.

Communication

The RMP communicates over three interfaces: Controller Area Network (CAN), Universal Serial Bus (USB), and Ethernet User Datagram Protocol (UDP). The messaging structure is similar across all three interfaces, with the only difference being the addition of a CRC-16 for the USB and UDP interfaces. For the C/C++ implementation of the CRC algorithm, see "Cyclic Redundancy Check (CRC)-16," p. 68.

The RMP communicates using a polling method. It requires the host to send a command packet to which the RMP will respond with a data packet containing all the present system information defined by the user.

The update frequency must fall within the range of 0.5Hz - 100Hz. If the commands are updated slower than the minimum rate, the commands will timeout and the user will experience intermittent motion. If commands are issued faster than the maximum rate, the commands will be ignored as if the host is not present.

For USB and UDP: if the command packet CRC is not valid, the RMP will ignore the command. See "Cyclic Redundancy Check (CRC)-16," p. 68, for details on how to calculate a command packet CRC.

The response packet is formed using the User Defined Feedback Bitmaps. It is important that the user understand how this works before trying to interpret the feedback packets. Please see "RMP Response," p. 56, for details.

Much of the information contained in this section is also available in `system_defines.py` as part of the RMP Demo OCU source code.

WARNING!

The user has the ability to change configuration variables and machine limits in a range from zero to maximum. Care must be taken when setting these limits as they could result in damage or injury. For example if the deceleration rate is set to 0 the RMP will not stop. This is to allow for maximum flexibility but also requires that users be especially careful when setting the parameters.

The following shorthand will be used to represent the different types of numbers used when communicating with the RMP:

Table 18: Number Types

Shorthand	Definition
Float32	32-bit floating point number represented as a IEEE754 32-bit integer ¹
S16_T	16-bit signed integer
U16_T	16-bit unsigned integer
U32_T	32-bit unsigned integer

¹ See "IEEE754 32-bit Floating Point and Integer Representation," p. 67.

General Command Structure

This section describes how commands are structured. CAN is described alone; USB and UDP are described together.

Each time a valid command is received, the RMP will send a response packet. See "RMP Response," p. 56, for details about the response packet.

The RMP only accepts one command per frame.

There are two types of commands: motion commands and configuration commands. Motion commands are used to send normalized velocity and yaw rate commands to the platform. Configuration commands are used to send non-motion machine parameters – such as changing modes and setting parameters.

There are two types of motion commands: standard motion commands and omni motion commands. Standard motion commands apply to models with standard tires. Omni motion commands only apply to models with mecanum wheels. Because of the unique geometry of the mecanum wheels, omni platforms can move left and right without turning, making them fully omni-directional.

CAN

The CAN interface is structured as in Table 19.

Each CAN command always contains a Message ID, a data length code, and two 32-bit values.

Message ID = 11-bit CAN identifier
 Data Length = 8
 Value 1 = Data[0] – Data[3]
 Value 2 = Data[4] – Data[7]

Value 1 and Value 2 are assembled as such:

```
Value1 = U32_T ((byte0 << 24) & 0xFF000000) |
            ((byte1 << 16) & 0x00FF0000) |
            ((byte2 << 8) & 0x0000FF00) |
            (byte3 & 0x000000FF);

Value2 = U32_T ((byte4 << 24) & 0xFF000000) |
            ((byte5 << 16) & 0x00FF0000) |
            ((byte6 << 8) & 0x0000FF00) |
            (byte7 & 0x000000FF);
```

Table 19: CAN Message Structure

Item	Description
Baud Rate	1 Mbps
Message ID	Standard 11-bit CAN identifier
Data Length	Always 8
Data Bytes	Bytes 0-3: Value 1 Bytes 4-7: Value 2

General Command Structure (cont.)

USB and UDP

The USB interface acts as a standard Serial RS232 emulator. The Ethernet interface uses User Datagram Protocol (UDP). The structure for messaging over both interfaces is the same.

Each command packet always contains a Message ID, two 32-bit values, and a CRC-16.

Message ID = Data[0] – Data[1]
 Value 1 = Data[2] – Data[5]
 Value 2 = Data[6] – Data[9]
 CRC-16 = Data[10] – Data[11]

The packet is assembled as such:

Message ID = U16_T ((byte0 << 8) & 0xFF00) |
 (byte1 & 0x00FF);
 Value1 = U32_T ((byte2 << 24) & 0xFF000000) |
 ((byte3 << 16) & 0x00FF0000) |
 ((byte4 << 8) & 0x0000FF00) |
 (byte5 & 0x000000FF);
 Value2 = U32_T ((byte6 << 24) & 0xFF000000) |
 ((byte7 << 16) & 0x00FF0000) |
 ((byte8 << 8) & 0x0000FF00) |
 (byte9 & 0x000000FF);
 CRC-16 = U16_T ((byte10 << 8) & 0xFF00) |
 (byte11 & 0x00FF);

Table 20: USB and UDP Message Structure

Item	Description
Data Length	Always 12
Message ID	Bytes 0-1
Data Bytes	Bytes 2-5: Value 1 Bytes 6-9: Value 2
CRC-16	Bytes 10-11: 16-bit CRC

Message ID

The Message ID is used to distinguish between the various types of messages sent to/from the RMP. Message types include Standard Motion Commands (page 39), Omni Motion Commands (page 40), Configuration Commands (page 42), and UDFB Response messages (page 56). The following table provides a list of possible Message IDs.

Table 21: Message IDs

Message ID	Description
0x0500	Standard Motion Command
0x0600	Omni Motion Command
0x0501	Configuration Command
0x0502 ¹	RMP Response 1
0x0503 ¹	RMP Response 2
0x0504 ¹	RMP Response 3
0x0505 ¹	RMP Response 4
... ¹	RMP Response ...

¹ CAN response only.

Standard Motion Commands

Standard motion commands control models with tires (not mecanum wheels). A standard RMP cannot use mecanum wheels.

The motion command packet is used to command machine velocity and yaw rate. The commands are normalized (-1.0–1.0). The command variable format is Float32. The normalized values are scaled against the user configurable parameters associated with the controller. The parameter against which the command is scaled depends on the input mapping type. For details on input mapping see "Controller Input Mapping," p. 53.

The basic motion command structure is shown in Table 22. Both variables are formatted as Float32 with a range of -1.0–1.0. For details on converting floating point values to integer representation in IEEE754 format, see "IEEE754 32-bit Floating Point and Integer Representation," p. 67.

Table 22: Standard Motion Command Structure

Item	Description
Message ID	0x0500
Variable 1	Normalized Velocity
Variable 2	Normalized Yaw Rate

CAN

Motion commands sent on the CAN interface follow the structure listed in Table 23.

Example:

```
vel_cmd   = 0.75 (0x3F400000 IEEE754 integer representation)
yaw_cmd   = 0.25 (0x3E800000 IEEE754 integer representation)
```

Example packet:

```
Message ID = 0x0500
Data Length = 8
Data[0]    = 0x3F
Data[1]    = 0x40
Data[2]    = 0x00
Data[3]    = 0x00
Data[4]    = 0x3E
Data[5]    = 0x80
Data[6]    = 0x00
Data[7]    = 0x00
```

Table 23: CAN Standard Motion Commands

Item	Description
Baud Rate	1 Mbps
Message ID	0x0500
Data Length	8
Data[0] – Data[3]	Normalized Velocity
Data[4] – Data[7]	Normalized Yaw Rate

USB and UDP

The USB and UDP interfaces mimic the CAN interface with the addition of a CRC-16. The packet is sent in a byte array. See the command structure shown in Table 24.

Example:

```
vel_cmd   = 0.75 (0x3F400000 IEEE754 integer representation)
yaw_cmd   = 0.25 (0x3E800000 IEEE754 integer representation)
```

Example packet:

```
Data[0]    = 0x05
Data[1]    = 0x00
Data[2]    = 0x3F
Data[3]    = 0x40
Data[4]    = 0x00
Data[5]    = 0x00
Data[6]    = 0x3E
Data[7]    = 0x80
Data[8]    = 0x00
Data[9]    = 0x00
Data[10]   = 0x80
Data[11]   = 0x1E
```

Table 24: USB and UDP Standard Motion Commands

Item	Description
Packet Length	12 bytes
Data[0] – Data[1]	0x0500 (Message ID)
Data[2] – Data[5]	Normalized Velocity
Data[6] – Data[9]	Normalized Yaw Rate
Data[10] – Data[11]	CRC-16

Omni Motion Commands

Omni motion commands control models with mecanum wheels (not tires). An omni-directional RMP cannot use tires.

The motion command packet is used to command machine velocity and yaw rate. The commands are normalized and scaled to 16 bits (-32768–32768), then packed into a U32_T. The normalized values are scaled against the user configurable parameters associated with the controller.

Example:

```

vel_cmd_f   = -1.0-1.0;
yaw_cmd_f   = -1.0-1.0;
Q15         = 32767;
vel_cmd     = (S16_T)(vel_cmd_f × Q15);
yaw_cmd     = (S16_T)(yaw_cmd_f × Q15);
Value1 = (U32_T)(((vel_cmd << 16) & 0xFFFF0000) | (yaw_cmd & 0x0000FFFF));
    
```

The angle command variable format is Float32. The angle command is not normalized and has a range of 0°–360°.

The basic motion command structure is shown in Table 25. Variables 1 High and 1 Low are formatted as S16_T with a range of -32768–32768. Variable 2 is formatted Float32 with a range of 0°–360°.

For details on converting floating point values to integer representation in IEEE754 format, see "IEEE754 32-bit Floating Point and Integer Representation," p. 67.

Table 25: Omni Motion Command Structure

Item	Description
Message ID	0x0600
Value 1 High	Normalized Scaled Velocity
Value 1 Low	Normalized Scaled Yaw Rate
Value 2	Angle

CAN

Motion commands sent on the CAN interface follow the structure listed in Table 26.

Example:

```

vel_cmd   = 0.75 (0.75 × 32767 = 24575 = 0x5FFF)
yaw_cmd   = 0.25 (0.25 × 32767 = 8191 = 0x1FFF)
angle_cmd = 45.0 (0x42340000 IEEE754 integer representation)
    
```

Example packet:

```

Message ID = 0x0600
Data Length = 8
Data[0]    = 0x5F
Data[1]    = 0xFF
Data[2]    = 0x1F
Data[3]    = 0xFF
Data[4]    = 0x42
Data[5]    = 0x34
Data[6]    = 0x00
Data[7]    = 0x00
    
```

Table 26: CAN Omni Motion Commands

Item	Description
Baud Rate	1 Mbps
Message ID	0x0600
Data Length	8
Data[0] – Data[1]	Normalized Scaled Velocity
Data[2] – Data[3]	Normalized Scaled Yaw Rate
Data[4] – Data[7]	Angle

Omni Motion Commands (cont.)

USB and UDP

The USB and UDP interfaces mimic the CAN interface with the addition of a CRC-16. The packet is sent in a byte array. See Table 27.

Example:

```

vel_cmd   = 0.75 (0.75 × 32767 = 24575 = 0x5FFF)
yaw_cmd   = 0.25 (0.25 × 32767 = 8191 = 0x1FFF)
angle_cmd = 45.0 (0x42340000 IEEE754 integer representation)

```

Example packet:

```

Data[0] = 0x06
Data[1] = 0x00
Data[2] = 0x5F
Data[3] = 0xFF
Data[4] = 0x1F
Data[5] = 0xFF
Data[6] = 0x42
Data[7] = 0x34
Data[8] = 0x00
Data[9] = 0x00
Data[10] = 0xAE
Data[11] = 0x19

```

Table 27: USB and UDP Omni Motion Commands

Item	Description
Packet Length	12 bytes
Data[0] – Data[1]	0x0600 (Message ID)
Data[2] – Data[3]	Normalized Scaled Velocity
Data[4] – Data[5]	Normalized Scaled Yaw Rate
Data[6] – Data[9]	Angle
Data[10] – Data[11]	CRC-16

Configuration Commands

The configuration command is used to perform a variety of functions, including: requesting mode transitions, retrieving the fault log, resetting position data, setting stored configurable parameters in non-volatile memory, and requesting audio tones.

Configuration parameters — which are set using configuration commands — are stored in Non-Volatile Memory (NVM). These values are pulled from memory at startup and used to initialize various parameters in the system. Once a value is set in NVM the value does not need to be set again unless it needs to be changed.

Configuration commands are composed of two variables:

- Value 1 (command ID) is formatted as U32_T.
- Value 2 (parameter) is 32 bits long; its format depends on the command being issued.

The command ID is always a 32-bit unsigned integer (U32_T).

CAN

Configuration commands sent on the CAN interface follow the structure listed in Table 29.

Example:

```
gp_cmd = RMP_CMD_SET_OPERATIONAL_MODE (0x00000020)
gp_param = TRACTOR_REQUEST (format: integer, 0x00000005)
```

Example packet:

```
Message ID = 0x0501
Data Length = 8
Data[0] = 0x00
Data[1] = 0x00
Data[2] = 0x00
Data[3] = 0x20
Data[4] = 0x00
Data[5] = 0x00
Data[6] = 0x00
Data[7] = 0x05
```

USB and UDP

The USB and UDP interfaces mimic the CAN interface with the addition of a CRC-16. The packet is sent in a byte array. See the command structure shown in Table 30.

Example:

```
gp_cmd = RMP_CMD_SET_OPERATIONAL_MODE (0x00000020)
gp_param = TRACTOR_REQUEST (format: integer, 0x00000005)
```

Example packet:

```
Data[0] = 0x05
Data[1] = 0x01
Data[2] = 0x00
Data[3] = 0x00
Data[4] = 0x00
Data[5] = 0x20
Data[6] = 0x00
Data[7] = 0x00
Data[8] = 0x00
Data[9] = 0x05
Data[10] = 0xD4
Data[11] = 0x51
```

Table 28: Configuration Command Structure

Item	Description
Message ID	0x0501
Value 1	Command ID.
Value 2	Parameter.

Table 29: CAN Configuration Commands

Item	Description
Baud Rate	1 Mbps
Message ID	0x0501
Data Length	8
Data[0] – Data[3]	Command ID
Data[4] – Data[7]	Parameter

Table 30: USB and UDP Configuration Commands

Item	Description
Packet Length	12 bytes
Data[0] – Data[1]	0x0501 (Message ID)
Data[2] – Data[5]	Command ID
Data[6] – Data[9]	Parameter
Data[10] – Data[11]	CRC-16

Configuration Commands (cont.)

RMP_CMD_NONE

This command is used to poll the RMP for data without issuing a command that will result in an action. This command does nothing, but is valid and will solicit a response.

Command ID: 0
Parameter Type: U32_T
Parameter Range: 0 (value ignored)
Parameter Units: Unitless
Stored in NVM: No
Default Value: N/A

RMP_CMD_SET_MAXIMUM_VELOCITY

This command is used to set the user defined maximum velocity limit. See "Controller Input Mapping," p. 53, for how this value will affect velocity commands.

Command ID: 1
Parameter Type: Float32
Parameter Range: 0.0–8.047
Parameter Units: m/s
Stored in NVM: Yes
Default Value: 2.2357

RMP_CMD_SET_MAXIMUM_ACCELERATION

This command is used to set the user defined maximum acceleration limit. See "Controller Input Mapping," p. 53, for how this value will affect velocity commands.

Command ID: 2
Parameter Type: Float32
Parameter Range: 0.0–7.848
Parameter Units: m/s²
Stored in NVM: Yes
Default Value: 3.923

RMP_CMD_SET_MAXIMUM_DECELERATION

WARNING!

Setting the maximum deceleration limit to zero will result in the machine not being able to stop. This could cause death, serious injury, or property damage.

This command is used to set the user defined maximum deceleration limit. See "Controller Input Mapping," p. 53, for how this value will affect velocity commands.

Command ID: 3
Parameter Type: Float32
Parameter Range: 0.0–7.848
Parameter Units: m/s²
Stored in NVM: Yes
Default Value: 3.923

Configuration Commands (cont.)

RMP_CMD_SET_MAXIMUM_DTZ_DECEL_RATE**⚠ WARNING!**

Setting the maximum Decel To Zero (DTZ) deceleration limit to zero will result in the machine not being able to stop during DTZ. This could cause death, serious injury, or property damage.

This command is used to set the user defined maximum Decel To Zero (DTZ) deceleration rate. When a DTZ is commanded — either via a mode command, through hardware, or as a fault response — this is the maximum rate at which the machine will come to a stop.

Command ID: 4
Parameter Type: Float32
Parameter Range: 0.0–7.848
Parameter Units: m/s²
Stored in NVM: Yes
Default Value: 3.923

RMP_CMD_SET_COASTDOWN_ACCEL**⚠ WARNING!**

Setting the coastdown acceleration to zero will result in the machine maintaining constant velocity even when no velocity is commanded when using acceleration-based input mapping. This could cause death, serious injury, or property damage.

This command is used to set the user defined coastdown acceleration value for acceleration-based input mapping. See "Controller Input Mapping," p. 53, for how this value will affect velocity commands.

Command ID: 5
Parameter Type: Float32
Parameter Range: 0.0–1.961
Parameter Units: m/s²
Stored in NVM: Yes
Default Value: 1.961

RMP_CMD_SET_MAXIMUM_TURN_RATE**⚠ WARNING!**

Setting the maximum turn rate to zero will result in the RMP not being able to turn. This could cause death, serious injury, or property damage.

This command is used to set the user defined yaw rate limit. See "Controller Input Mapping," p. 53, for how this value will affect yaw rate commands.

Command ID: 6
Parameter Type: Float32
Parameter Range: 0.0–4.5
Parameter Units: rad/s
Stored in NVM: Yes
Default Value: 3.0

Configuration Commands (cont.)

RMP_CMD_SET_MAXIMUM_TURN_ACCEL

⚠ WARNING!

Setting the maximum turn acceleration to zero will result in the RMP not being able to turn. This could cause death, serious injury, or property damage.

This command is used to set the user defined yaw acceleration limit. This value limits the rate at which the yaw rate target can change.

Command ID: 7
Parameter Type: Float32
Parameter Range: 0.0–28.274
Parameter Units: rad/s²
Stored in NVM: Yes
Default Value: 28.274

RMP_CMD_SET_TIRE_DIAMETER

⚠ WARNING!

This value must match the actual tire diameter on the RMP. Failure to do so will result in undetermined behavior and invalid feedback. This could cause death, serious injury, or property damage.

This command updates the tire diameter used in software to calculate velocity, acceleration, position, and differential wheel speed (yaw rate). The RMP must be power cycled (rebooted) for the change to take effect.

Command ID: 8
Parameter Type: Float32
Parameter Range: 0.3556–1.0
Parameter Units: m
Stored in NVM: Yes
Default Value: 0.483616

RMP_CMD_SET_WHEEL_BASE_LENGTH

⚠ WARNING!

This value must match the actual wheel base length on the RMP. Failure to do so will result in undetermined behavior and invalid feedback. This could cause death, serious injury, or property damage.

This command updates the wheel base length (fore/aft distance between the tires) used in software to calculate lateral acceleration and differential wheel speed (yaw rate). The RMP must be power cycled (rebooted) for the change to take effect.

Command ID: 9
Parameter Type: Float32
Parameter Range: 0.4142–1.0
Parameter Units: m
Stored in NVM: Yes
Default Value: 0.5842

Configuration Commands (cont.)

RMP_CMD_SET_WHEEL_TRACK_WIDTH**⚠ WARNING!**

This value must match the actual track width on the RMP. Failure to do so will result in undetermined behavior and invalid feedback. This could cause death, serious injury, or property damage.

This command updates the track width (lateral distance between the tires) used in software to calculate lateral acceleration and differential wheel speed (yaw rate). The RMP must be power cycled (rebooted) for the change to take effect.

Command ID: 10
 Parameter Type: Float32
 Parameter Range: 0.506476–1.0
 Parameter Units: m
 Stored in NVM: Yes
 Default Value: 0.7112

RMP_CMD_SET_TRANSMISSION_RATIO**⚠ WARNING!**

This value must match the actual gear ratio on the RMP. Failure to do so will result in undetermined behavior and invalid feedback. This could cause death, serious injury, or property damage.

This command updates the gearbox (transmission) ratio. It is used in software to convert from motor speed to gearbox output speed. The RMP must be power cycled (rebooted) for the change to take effect.

Command ID: 11
 Parameter Type: Float32
 Parameter Range: 1.0–200.0
 Parameter Units: Unitless
 Stored in NVM: Yes
 Default Value: 24.2667

RMP_CMD_SET_INPUT_CONFIG_BITMAP

This command updates RMP behavior configurations. It updates the input mapping, audio silence settings, and whether to check and warn for charger present at startup. When the audio silence bit is set the RMP will become silent and not issue any audio indications. For an explanation of input mapping see "Controller Input Mapping," p. 53.

Command ID: 12
 Parameter Type: U32_T
 Parameter Range: 0x0000000F (valid mask)
 Parameter Units: Unitless
 Stored in NVM: Yes
 Default Value: 0x00000001

```
YAW_ALAT_SCALE_MAPPING      = 0;
YAW_ALAT_LIMIT_MAPPING     = 1;

VELOCITY_BASED_MAPPING      = 0;
ACCELERATION_BASED_MAPPING = 1;

ALLOW_MACHINE_AUDIO        = 0;
SILENCE_MACHINE_AUDIO      = 1;

ENABLE_AC_PRESENT_CSI      = 0;
DISABLE_AC_PRESENT_CSI     = 1;

YAW_INPUT_MAPPING_SHIFT    = 0;
VEL_INPUT_MAPPING_SHIFT    = 1;
AUDIO_SILENCE_REQUEST_SHIFT = 2;
DISABLE_AC_PRESENT_CSI_SHIFT = 3;
```

Configuration Commands (cont.)

```
DEFAULT_CONFIG_BITMAP = ((YAW_ALAT_LIMIT_MAPPING << YAW_INPUT_MAPPING_SHIFT) |
                          (VELOCITY_BASED_MAPPING << VEL_INPUT_MAPPING_SHIFT) |
                          (ALLOW_MACHINE_AUDIO << AUDIO_SILENCE_REQUEST_SHIFT) |
                          (ENABLE_AC_PRESENT_CSI << DISABLE_AC_PRESENT_CSI_SHIFT));
```

RMP_CMD_SET_ETH_IP_ADDRESS

This command updates the Ethernet IP address on the RMP. The parameter must be converted from a dotted quad address to integer representation. The RMP must be power cycled (rebooted) for the address change to take effect.

Command ID: 13
 Parameter Type: U32_T
 Parameter Range: Valid IP Address
 Parameter Units: Unitless
 Stored in NVM: Yes
 Default Value: 0x2800A8C0 (192.168.0.40)

$integer = (first\ octet \times 16777216) + (second\ octet \times 65536) + (third\ octet \times 256) + (fourth\ octet)$

For the IP address 192.168.0.40:

$integer = (40 \times 16777216) + (0 \times 65536) + (168 \times 256) + (192) = 0x2800A8C0$

RMP_CMD_SET_ETH_PORT_NUMBER

This command updates the Ethernet IP port number for the PC-to-RMP connection. Both the host computer and the RMP must communicate over this port. The RMP must be power cycled (rebooted) for the change to take effect.

Command ID: 14
 Parameter Type: U32_T
 Parameter Range: Valid Ethernet Port Number
 Parameter Units: Unitless
 Stored in NVM: Yes
 Default Value: 8080

RMP_CMD_SET_ETH_SUBNET_MASK

This command updates the Ethernet IP subnet mask of the RMP. The parameter must be converted from a dotted quad address to integer representation. The RMP must be power cycled (rebooted) for the change to take effect.

Command ID: 15
 Parameter Type: U32_T
 Parameter Range: Valid IP Subnet Mask
 Parameter Units: Unitless
 Stored in NVM: Yes
 Default Value: 0x00FFFFFF (255.255.255.0)

$integer = (first\ octet \times 16777216) + (second\ octet \times 65536) + (third\ octet \times 256) + (fourth\ octet)$

For the IP subnet mask 255.255.255.0:

$integer = (0 \times 16777216) + (255 \times 65536) + (255 \times 256) + (255) = 0x00FFFFFF$

Configuration Commands (cont.)

RMP_CMD_SET_ETH_GATEWAY

This command updates the Ethernet IP gateway address of the RMP. The parameter must be converted from a dotted quad address to integer representation. The RMP must be power cycled (rebooted) for the change to take effect.

Command ID: 16
Parameter Type: U32_T
Parameter Range: Valid IP Gateway Address
Parameter Units: Unitless
Stored in NVM: Yes
Default Value: 0x0100A8C0 (192.168.0.1)

$\text{integer} = (\text{first octet} \times 16777216) + (\text{second octet} \times 65536) + (\text{third octet} \times 256) + (\text{fourth octet})$

For the IP gateway address 192.168.0.1:

$\text{integer} = (1 \times 16777216) + (0 \times 65536) + (168 \times 256) + (192) = 0x0100A8C0$

RMP_CMD_SET_USER_FB_1_BITMAP

This command updates the User Defined Feedback Bitmap 1. It is used to select feedback from the list of variables defined in "User Defined Feedback Bitmap 1," p. 60. See "User Defined Feedback Bitmaps," p. 56, for details on how these bitmaps work.

Command ID: 17
Parameter Type: U32_T
Parameter Range: 0xFFFFFFFF (valid mask)
Parameter Units: Unitless
Stored in NVM: Yes
Default Value: 0xFFFFFFFF

RMP_CMD_SET_USER_FB_2_BITMAP

This command updates the User Defined Feedback Bitmap 2. It is used to select feedback from the list of variables defined in "User Defined Feedback Bitmap 2," p. 62. See "User Defined Feedback Bitmaps," p. 56, for details on how these bitmaps work.

Command ID: 18
Parameter Type: U32_T
Parameter Range: 0xFFFFFFFF (valid mask)
Parameter Units: Unitless
Stored in NVM: Yes
Default Value: 0xFFFFFFFF

RMP_CMD_SET_USER_FB_3_BITMAP

This command updates the User Defined Feedback Bitmap 3. It is used to select feedback from the list of variables defined in "User Defined Feedback Bitmap 3," p. 64. See "User Defined Feedback Bitmaps," p. 56, for details on how these bitmaps work.

Command ID: 19
Parameter Type: U32_T
Parameter Range: 0xFFFFFFFF (valid mask)
Parameter Units: Unitless
Stored in NVM: Yes
Default Value: 0xFFFFFFFF

Configuration Commands (cont.)**RMP_CMD_SET_USER_FB_4_BITMAP**

This command updates the User Defined Feedback Bitmap 4. It is used to select feedback from the list of variables defined in "User Defined Feedback Bitmap 4," p. 66. See "User Defined Feedback Bitmaps," p. 56, for details on how these bitmaps work.

Command ID: 20
Parameter Type: U32_T
Parameter Range: 0x00000000 (valid mask)
Parameter Units: Unitless
Stored in NVM: Yes
Default Value: 0x00000000

RMP_CMD_FORCE_CONFIG_FEEDBACK_BITMAPS

This command forces the feedback to contain all the configurable parameters stored in NVM. It is used when verifying that parameters have been successfully set and for general verification at startup. Set this parameter to 1 to force all feedback to contain configurable items; set it to 0 to stop forcing the feedback.

Command ID: 30
Parameter Type: U32_T
Parameter Range: 0 or 1
Parameter Units: Boolean
Stored in NVM: No
Default Value: N/A

When this command is set to 1, the response will contain the following:

feedback1 = 0x00000000
feedback2 = 0x00000000
feedback3 = 0xFFFFF000
feedback4 = 0x00000000

Responses thereafter will contain this data until the parameter is set to 0, at which point the feedback reverts to the user-defined feedback. See "User Defined Feedback Bitmaps," p. 56, for details.

Configuration Commands (cont.)

RMP_CMD_SET_AUDIO_COMMAND

This command requests an audio song from the RMP motor unit. If the RMP determines that it is able to play the song it will do so. If it is internally using the audio or the current limit is folded back, the RMP will not play the commanded audio.

Audio song requests should be momentary (i.e. they only need to be sent once). The songs that are not persistent will be cleared by the CCU. If the song is persistent it must be cleared by sending the MOTOR_AUDIO_PLAY_NO_SONG parameter. See Table 31 for a list of available audio songs.

Command ID: 31
 Parameter Type: U32_T
 Parameter Range: 0–16
 Parameter Units: Unitless
 Stored in NVM: No
 Default Value: N/A

Table 31: Audio Songs

Audio Song	Value	Must Be Cleared?
MOTOR_AUDIO_PLAY_NO_SONG	0	No
MOTOR_AUDIO_PLAY_POWER_ON_SONG	1	No
MOTOR_AUDIO_PLAY_POWER_OFF_SONG	2	No
MOTOR_AUDIO_PLAY_ALARM_SONG	3	No
MOTOR_AUDIO_PLAY_MODE_UP_SONG	4	No
MOTOR_AUDIO_PLAY_MODE_DOWN_SONG	5	No
MOTOR_AUDIO_PLAY_ENTER_ALARM_SONG	6	No
MOTOR_AUDIO_PLAY_EXIT_ALARM_SONG	7	No
MOTOR_AUDIO_PLAY_FINAL_SHUTDOWN_SONG	8	No
MOTOR_AUDIO_PLAY_CORRECT_ISSUE	9	No
MOTOR_AUDIO_PLAY_ISSUE_CORRECTED	10	No
MOTOR_AUDIO_PLAY_CORRECT_ISSUE_REPEATING	11	Yes
MOTOR_AUDIO_PLAY_BEGINNER_ACK	12	No
MOTOR_AUDIO_PLAY_EXPERT_ACK	13	No
MOTOR_AUDIO_ENTER_FOLLOW	14	No
MOTOR_AUDIO_TEST_SWEEP	15	No
MOTOR_AUDIO_SIMULATE_MOTOR_NOISE	16	Yes

RMP_CMD_SET_OPERATIONAL_MODE

This command is used to request mode transitions for the RMP. The modes are listed in Table 32. The persistence of the request is managed internally by the CCU (i.e., the command need only be sent once). For more information on modes, see "Operational Model," p. 24.

Command ID: 32
 Parameter Type: U32_T
 Parameter Range: 1–5
 Parameter Units: Unitless
 Stored in NVM: No
 Default Value: N/A

Table 32: Operational Mode Requests

Mode Request	Parameter Value	Valid From
DISABLE_REQUEST	1	Any State
POWERDOWN_REQUEST	2	Any State
DTZ_REQUEST	3	Any State
STANDBY_REQUEST	4	Tractor Mode
TRACTOR_REQUEST	5	Standby Mode

Configuration Commands (cont.)

RMP_CMD_SEND_SP_FAULTLOG

This command is used to request the faultlog from the RMP. Setting the parameter to 1 indicates a new request; 0 indicates a subsequent request. The entire faultlog requires six packets: the first request should have the parameter set to 1; the next five requests should have the parameter set to 0.

See `faultlog_extractor.py` in the RMP Demo OCU source code for details on extracting and parsing the faultlog.

Command ID: 33
 Parameter Type: U32_T
 Parameter Range: 0 or 1
 Parameter Units: Boolean
 Stored in NVM: No
 Default Value: N/A

RMP_CMD_RESET_INTEGRATORS

This command is used to reset the position data on the RMP. The parameter is a bitmap of which integrators to reset. See Table 33 for details about the bitmap.

Command ID: 34
 Parameter Type: U32_T
 Parameter Range: 0x0000001F (valid mask)
 Parameter Units: Unitless
 Stored in NVM: No
 Default Value: N/A

Table 33: Position Reset Bitmap

Data to Reset	Value
RESET_LINEAR_POSITION	0x00000001
RESET_RIGHT_FRONT_POSITION	0x00000002
RESET_LEFT_FRONT_POSITION	0x00000004
RESET_RIGHT_REAR_POSITION	0x00000008
RESET_LEFT_REAR_POSITION	0x00000010
RESET_ALL_POSITION_DATA	0x0000001F

RMP_CMD_RESET_PARAMS_TO_DEFAULT

This command is used to reset all the parameters stored in NVM to their default values.

Command ID: 35
 Parameter Type: U32_T
 Parameter Range: 0 (value ignored)
 Parameter Units: Unitless
 Stored in NVM: No
 Default Value: N/A

NOTE:

Some parameters (including Ethernet settings, tire diameter, wheel base, track width, and transmission ratio) will not take effect until after the machine has been power cycled (rebooted).

Configuration Commands (cont.)

The table below provides a list of all the configuration commands and their parameters.

Table 34: Configuration Commands

Command Name	ID	Type	Range	Units	Stored in NVM?	Default Value
RMP_CMD_NONE	0	U32_T	0 (value ignored)	Unitless	No	N/A
RMP_CMD_SET_MAXIMUM_VELOCITY	1	Float32	0.0–8.047	m/s	Yes	2.2352
RMP_CMD_SET_MAXIMUM_ACCELERATION	2	Float32	0.0–7.848	m/s ²	Yes	3.923
RMP_CMD_SET_MAXIMUM_DECELERATION	3	Float32	0.0–7.848	m/s ²	Yes	3.923
RMP_CMD_SET_MAXIMUM_DTZ_DECEL_RATE	4	Float32	0.0–7.848	m/s ²	Yes	3.923
RMP_CMD_SET_COASTDOWN_ACCEL	5	Float32	0.0–1.961	m/s ²	Yes	1.961
RMP_CMD_SET_MAXIMUM_TURN_RATE	6	Float32	0.0–4.5	rad/s	Yes	3.0
RMP_CMD_SET_MAXIMUM_TURN_ACCEL	7	Float32	0.0–28.274	rad/s ²	Yes	28.274
RMP_CMD_SET_TIRE_DIAMETER ¹	8	Float32	0.3556–1.0	m	Yes	0.483616
RMP_CMD_SET_WHEEL_BASE_LENGTH	9	Float32	0.4142–1.0	m	Yes	0.5842
RMP_CMD_SET_WHEEL_TRACK_WIDTH ¹	10	Float32	0.506476–1.0	m	Yes	0.7112
RMP_CMD_SET_TRANSMISSION_RATIO ¹	11	Float32	1.0–200.0	Unitless	Yes	24.2667
RMP_CMD_SET_INPUT_CONFIG_BITMAP	12	U32_T	0x0000000F (valid mask)	Unitless	Yes	0x1
RMP_CMD_SET_ETH_IP_ADDRESS ¹	13	U32_T	Valid IP Address	Unitless	Yes	0x2800A8C0 (192.168.0.40)
RMP_CMD_SET_ETH_PORT_NUMBER ¹	14	U32_T	Valid Ethernet Port Number	Unitless	Yes	8080
RMP_CMD_SET_ETH_SUBNET_MASK ¹	15	U32_T	Valid IP Subnet Mask	Unitless	Yes	0x00FFFFFF (255.255.255.0)
RMP_CMD_SET_ETH_GATEWAY ¹	16	U32_T	Valid IP Gateway Address	Unitless	Yes	0x0100A8C0 (192.168.0.1)
RMP_CMD_SET_USER_FB_1_BITMAP	17	U32_T	0xFFFFFFFF (valid mask)	Unitless	Yes	0xFFFFFFFF
RMP_CMD_SET_USER_FB_2_BITMAP	18	U32_T	0xFFFFFFFF (valid mask)	Unitless	Yes	0xFFFFFFFF
RMP_CMD_SET_USER_FB_3_BITMAP	19	U32_T	0x0FFFFFFF (valid mask)	Unitless	Yes	0x0FFFFFFF
RMP_CMD_SET_USER_FB_4_BITMAP	20	U32_T	0x00000000 (valid mask)	Unitless	Yes	0x00000000
RMP_CMD_FORCE_CONFIG_FEEDBACK_BITMAPS	30	U32_T	0 or 1	Boolean	No	N/A
RMP_CMD_SET_AUDIO_COMMAND	31	U32_T	0–16	Unitless	No	N/A
RMP_CMD_SET_OPERATIONAL_MODE	32	U32_T	1–5	Unitless	No	N/A
RMP_CMD_SEND_SP_FAULTLOG	33	U32_T	0 or 1	Boolean	No	N/A
RMP_CMD_RESET_INTEGRATORS	34	U32_T	0x0000001F (valid mask)	Unitless	No	N/A
RMP_CMD_RESET_PARAMS_TO_DEFAULT	35	U32_T	0 (value ignored)	Unitless	No	N/A

¹RMP must be power cycled for parameter to take effect.

Controller Input Mapping

The RMP has two input mapping methods for the velocity controller and two for the yaw controller. The type of mapping used for each controller can be set using the configuration command `RMP_SET_INPUT_CONFIG_BITMAP` (page 46).

The inputs to each controller are the normalized motion commands (see "Standard Motion Commands," p. 39). The commands are scaled depending on the input mapping selected for the machine. Each type of input mapping is described in detail below.

Velocity Controller, Velocity-Based Input Mapping

This type of input mapping is particularly useful for autonomous operation where direct velocity is desired to be commanded.

This type of input mapping proportionally scales the normalized velocity controller command to the velocity limit. The target is then rate limited by the acceleration and deceleration limits.

- As the velocity target moves away from zero, the maximum acceleration limit is applied.
- As the velocity target moves toward zero, the maximum deceleration limit is applied.

This means that — although the input can move stepwise — the target can only change at the rates specified in the NVM.

The following parameters affect velocity-based input mapping:

1. `RMP_CMD_SET_MAXIMUM_VELOCITY` — serves as the velocity limit.
2. `RMP_CMD_SET_MAXIMUM_ACCELERATION` — the value against which the normalized input command is scaled when the velocity target is moving away from zero velocity.
3. `RMP_CMD_SET_MAXIMUM_DECELERATION` — the value against which the normalized input command is scaled when the velocity target is moving toward zero velocity.

Velocity Controller, Acceleration-Based Input Mapping

This type of input mapping is primarily intended for teleoperation of the platform.

For this input mapping, the command is scaled by the user configurable acceleration or deceleration (depending on the sign of the command) and a desired acceleration is generated. Because the velocity controller requires a velocity target, this desired acceleration is integrated to produce the velocity target. Additionally, this "desired acceleration" command is attenuated as the machine approaches some region of operation near the velocity limit. This provides feedback to the driver that they are approaching the limit and helps to smooth the transition from accelerating to steady state at the speed limit.

Another characteristic is the coast-down behavior for zero input. Due to the nature of closed loop velocity control, a zero input is interpreted as zero acceleration and thus constant speed. A simplified way to think of it is that you are always running "cruise control." To get the desired behavior of a coast-down for zero input you add it in deliberately, summed into the "desired acceleration" from the normalized input. The coast-down acceleration needs to be managed appropriately with speed so it is always applied in the correct direction, opposing vehicle motion. One method of achieving this is to link the coast-down to system speed.

In acceleration-based input mapping it is also desirable to have some interlock between forward motion and reverse motion. This is due to the common input for acceleration and deceleration. When braking from speed the vehicle should not start moving backwards once it comes to zero speed. This can be accomplished through various means including a "gesture" of the input, analogous to a double tap or double click. This method requires returning the input command to zero before allowing a change in fore/aft direction.

The following parameters affect this type of input mapping:

1. `RMP_CMD_SET_MAXIMUM_VELOCITY` — serves as the velocity limit.
2. `RMP_CMD_SET_MAXIMUM_ACCELERATION` — the value against which the normalized input command is scaled when the velocity target is moving away from zero velocity.
3. `RMP_CMD_SET_MAXIMUM_DECELERATION` — the value against which the normalized input command is scaled when the velocity target is moving toward zero velocity.
4. `RMP_CMD_SET_COASTDOWN_ACCEL` — the rate at which the velocity target goes to zero with zero input command.

Controller Input Mapping (cont.)

Yaw Controller, Yaw Rate Limit-Based Input Mapping

This type of mapping is generally ideal for autonomous driving where the user wants – within limits – the same input sensitivity through all velocities.

This type of input mapping scales the normalized input against the yaw rate limit set in NVM. It saturates the yaw command to an envelope on the yaw-rate – linear-velocity plane. This envelope is derived from a maximum lateral acceleration limit of 1.0 g. In this mapping calculation, yaw rate is mapped linearly to input command and saturated at the envelope.

The plot of the yaw-rate target versus vehicle velocity for this input mapping is shown below, where the yaw rate target is a function of user command and vehicle velocity.

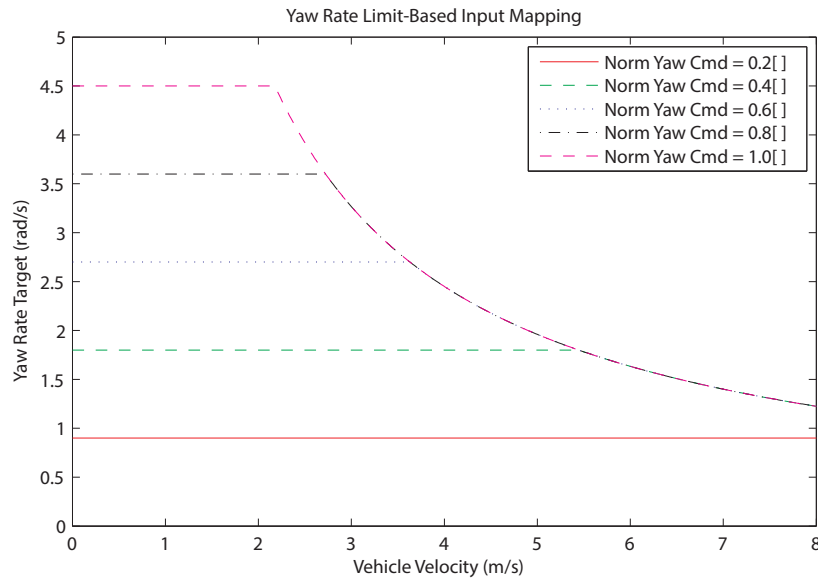

Figure 41: Yaw Rate Target vs. Vehicle Velocity: Limit-Based Mapping

There are two configurable parameters stored in NVM that affect this type of input mapping:

1. RMP_CMD_SET_MAXIMUM_TURN_RATE – the value against which the normalized input command is scaled to generate a desired yaw rate.
2. RMP_CMD_SET_MAXIMUM_TURN_ACCEL – the rate of change limit for the yaw rate target.

Controller Input Mapping (cont.)

Yaw Controller, Lateral Acceleration-Based Input Mapping

Lateral acceleration-based yaw controller input mapping is primarily intended for teleoperation of the platform.

This type of input mapping scales the normalized input against the lateral acceleration limit set in code (1.0 g). From the lateral acceleration command and the present velocity, a yaw rate command is generated. This reduces the yaw rate sensitivity of the input as the speed increases in order to keep the lateral acceleration sensitivity constant. It allows the user to utilize the full scale (-1.0 to 1.0) input command through the entire velocity range without saturating the yaw rate. This type of mapping is generally ideal for manual driving (direct or teleoperated) where the user wants to reduce input sensitivity to yaw rates as the speed increases (meaning for finer adjustments with larger input as speed increases). The plot of yaw rate target versus vehicle velocity for this input mapping is shown below, where the yaw rate target is a function of user command and vehicle velocity.

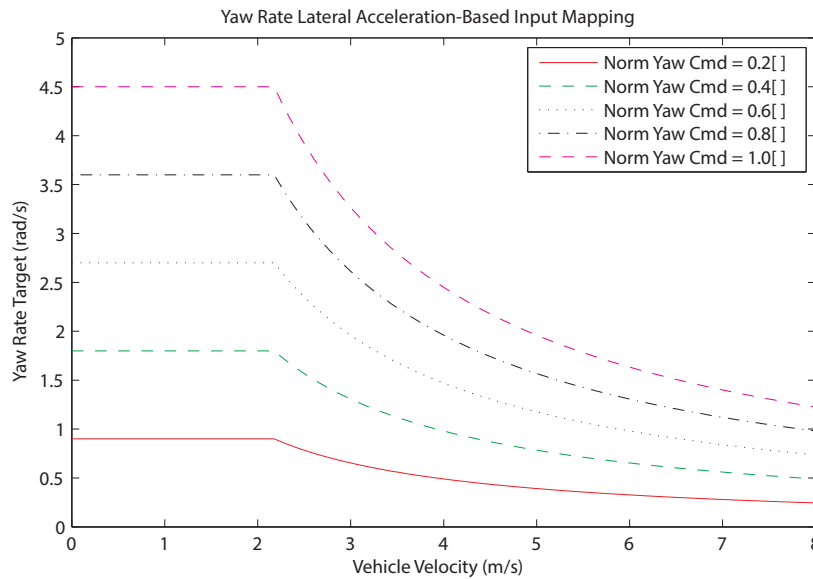

Figure 42: Yaw Rate Target vs. Vehicle Velocity: Lateral Acceleration-Based Mapping

There are two configurable parameters stored in NVM that affect this type of input mapping:

1. RMP_CMD_SET_MAXIMUM_TURN_RATE — this shifts the transition velocity and limits the target for the yaw rate.
2. RMP_CMD_SET_MAXIMUM_TURN_ACCEL — the rate of change limit for the yaw rate target.

RMP Response

For every valid command received, the RMP will respond with the data specified by the User Defined Feedback Bitmaps (UDFBs). It is important that one understands how the UDFBs function before trying to interpret the feedback in the response.

For details on setting these bitmaps see:

- "RMP_CMD_SET_USER_FB_1_BITMAP," p. 48.
- "RMP_CMD_SET_USER_FB_2_BITMAP," p. 48.
- "RMP_CMD_SET_USER_FB_3_BITMAP," p. 48.
- "RMP_CMD_SET_USER_FB_4_BITMAP," p. 49

For details regarding the data meaning, format, range, and description see the UDFB tables starting on page 60.

An RMP response will contain the data array of 32-bit values specified by the UDFBs plus a CRC-16. Although the CRC is only 16 bits, the RMP ships all values as 32 bits, including the CRC. The additional 16 bits are null bits placed in front of the CRC. These null bits must be included when calculating the CRC. For a C/C++ implementation of the CRC see "Cyclic Redundancy Check (CRC)-16," p. 68.

User Defined Feedback Bitmaps

There are 96 system variables that can be selected for feedback. Depending on the user application it may be desirable to receive all of them or only a subset of them. To facilitate this there are four User Defined Feedback Bitmaps. The UDFBs are stored in non-volatile memory and can be set using the methods described in "Configuration Commands," p. 42. This allows the user to set the User Defined Feedback Bitmaps once, and from then on the data in the response packet will be defined by those values.

For example, say a user only wants inertial data. The user would determine the corresponding bits to set in each bitmap. The user would send the configuration command to set the bitmaps to the desired values. From then on the response message would contain only the inertial data selected by the user.

If the user wishes to see all the data, the default values can be left alone and all 96 variables will be included in each response packet.

Each bit in each bitmap corresponds to a piece of data in an array. If one lines up the binary values for the UDFBs in order (UDFB1, UDFB2, UDFB3, UDFB4) there would be one 96-bit value with each bit representing one piece of data in the array. If the bit is set, the data will be broadcast in the next index; if the bit is cleared, the data will be skipped and the next set bit will determine the next piece of data in the response. The bitmap tables containing variable names, meaning, type, and range for each bit in each bitmap can be found starting on page 60.

Usage Examples

The following examples demonstrate the concept of the User Defined Feedback Bitmaps. First the UDFBs are set using the appropriate configuration commands (see page 48). Thereafter every RMP Response will contain the information specified by the UDFBs. Depending on whether the communication is over CAN, USB, or UDP the response may be multiple packets or a single large packet. The following examples demonstrate the connection between setting the bitmaps and the variables sent in the response.

Example 1

First set the UDFBs as shown below. Table 35 provides the information required to set UDFB1. Adjust the Command ID and Parameter as required when setting UDFB2, UDFB3, and UDFB4 (see page 48).

```
UDFB1 = 0x00000003 (bits 0-1)
UDFB2 = 0x00000000 (none)
UDFB3 = 0x00000000 (none)
UDFB4 = 0x00000000 (none)
```

Each command sent to the RMP will trigger a response message. The response message contains the values of the UDFB variables currently enabled plus a CRC-16.

Once all four UDFBs are set, the RMP response will contain these variables:
[UDFB1-bit0, UDFB1-bit1, CRC-16]

Or with variable names from the UDFB tables:
[fault_status_word_1, fault_status_word_2, CRC-16]

The structure of the response packet(s) is described in "CAN Response Structure," p. 58, and "USB and UDP Response Structure," p. 59.

Table 35: Setting UDFB1, Example 1

Item	Description
Message ID	0x0501
Command ID	0x00000017
Parameter	0x00000003.

Table 36: RMP Response, Example 1

Item	UDFB	Variable Name
Variable 1	UDFB1-bit0	fault_status_word_1
Variable 2	UDFB1-bit1	fault_status_word_2
Variable 3	—	0x0000, CRC-16

RMP Response (cont.)

Example 2

Set the UDFBs as shown below. Information on setting UDFBs is found in "Configuration Commands," p. 42. Information on the feedback bitmaps themselves is found on page 48. An example of how to set UDFB2 is shown in Table 37.

- UDFB1 = 0x00000003 (bits 0-1)
- UDFB2 = 0xF0000000 (bits 28-31)
- UDFB3 = 0x00000000 (none)
- UDFB4 = 0x00000000 (none)

After the UDFBs are set, all RMP response messages will contain the following variables:

- [UDFB1-bit0, UDFB1-bit1, UDFB2-bit28, UDFB2-bit29, UDFB2-bit30, UDFB2-bit31, CRC-16]

Or with variable names from the UDFB tables:

- [fault_status_word_1, fault_status_word_2, aux_batt_current_A, aux_batt_temp_degC, abb_system_status, aux_batt_status, CRC-16]

The structure of the response packet(s) is described in "CAN Response Structure," p. 58, and "USB and UDP Response Structure," p. 59.

Example 3

Set the UDFBs as shown below. Information on setting UDFBs is found in "Configuration Commands," p. 42. Information on the feedback bitmaps themselves is found on page 48. An example of how to set UDFB3 is shown in Table 39.

- UDFB1 = 0x80000001 (bits 0, 31)
- UDFB2 = 0x00008001 (bits 0, 15)
- UDFB3 = 0x00008030 (bits 4-5, 15)
- UDFB4 = 0x00000000 (none)

After the UDFBs are set, all RMP response messages will contain the following variables:

- [UDFB1-bit0, UDFB1-bit31, UDFB2-bit0, UDFB2-bit15, UDFB3-bit4, UDFB3-bit5, UDFB3-bit15, CRC-16]

Or with variable names from the UDFB tables:

- [fault_status_word_1, right_rear_vel_mps, left_rear_vel_mps, rear_base_batt_2_soc, mcu_0_inst_power_W, mcu_1_inst_power_W, fram_dtz_decel_limit_mps2, CRC-16]

The structure of the response packet(s) is described in "CAN Response Structure," p. 58, and "USB and UDP Response Structure," p. 59.

Table 37: Setting UDFB2, Example 2

Item	Description
Message ID	0x0501
Command ID	0x00000018
Parameter	0xF0000000

Table 38: RMP Response, Example 2

Item	UDFB	Variable Name
Variable 1	UDFB1-bit0	fault_status_word_1
Variable 2	UDFB1-bit1	fault_status_word_2
Variable 3	UDFB2-bit28	aux_batt_current_A
Variable 4	UDFB2-bit29	aux_batt_temp_degC
Variable 5	UDFB2-bit30	abb_system_status
Variable 6	UDFB2-bit31	aux_batt_status
Variable 7	—	0x0000, CRC

Table 39: Setting UDFB3, Example 3

Item	Description
Message ID	0x0501
Command ID	0x00000019
Parameter	0x00008030

Table 40: RMP Response, Example 3

Item	UDFB	Variable Name
Variable 1	UDFB1-bit0	fault_status_word_1
Variable 2	UDFB1-bit31	right_rear_vel_mps
Variable 3	UDFB2-bit0	left_rear_vel_mps
Variable 4	UDFB2-bit15	rear_base_batt_2_soc
Variable 5	UDFB3-bit4	mcu_0_inst_power_W
Variable 6	UDFB3-bit5	mcu_1_inst_power_W
Variable 7	UDFB3-bit15	fram_dtz_decel_limit_mps2
Variable 8	—	0x0000, CRC

RMP Response (cont.)

CAN Response Structure

The CAN interface is structured as in Table 41.

Each CAN message always contains two 32-bit values. The values are assembled as such:

```
Value1 = U32_T((byte0 << 24) & 0xFF000000) |
          ((byte1 << 16) & 0x00FF0000) |
          ((byte2 << 8) & 0x0000FF00) |
          (byte3 & 0x000000FF);
Value2 = U32_T((byte4 << 24) & 0xFF000000) |
          ((byte5 << 16) & 0x00FF0000) |
          ((byte6 << 8) & 0x0000FF00) |
          (byte7 & 0x000000FF);
```

Table 41: CAN Response Structure

Item	Description
Baud Rate	1 Mbps
Header	Standard 11-bit CAN identifier
Data Length	Always 8
Data Bytes	Bytes 0-3: Value 1 Bytes 4-7: Value 2

CAN response messages start with the Message ID. The first message in the CAN response will have a Message ID of 0x0502. This message will contain the first two 32-bit values in the response array. The Message ID will then increment by 1 and send the next two items. This process will continue until the entire array plus the CRC-16 has been sent.

If the length of the feedback array plus the CRC-16 is odd, the last message will contain the CRC-16 in value 1 and nothing in value 2. This is because two 32-bit values are sent in each message. In this case, value 2 should be discarded; it is not part of the array. For a C/C++ implementation of the CRC see "Cyclic Redundancy Check (CRC)-16," p. 68.

Example

Set the UDFBs as shown below. Information on setting UDFBs is found in "Configuration Commands," p. 42. Information on the feedback bitmaps themselves is found on page 48.

```
UDFB1 = 0x80000001 (bits 0, 31)
UDFB2 = 0x00008001 (bits 0, 15)
UDFB3 = 0x00008030 (bits 4-5, 15)
UDFB4 = 0x00000000 (none)
```

After the UDFBs are set, all RMP response messages will contain the following variables:

```
[UDFB1-bit0, UDFB1-bit31, UDFB2-bit0, UDFB2-bit15, UDFB3-bit4,
UDFB3-bit5, UDFB3-bit15, CRC-16]
```

Or with variable names from the UDFB tables:

```
[fault_status_word_1, right_rear_vel_mps, left_rear_vel_mps,
rear_base_batt_2_soc, mcu_0_inst_power_W, mcu_1_inst_power_W,
fram_dtz_decel_limit_mps2, CRC-16]
```

CAN response messages are broken into packets containing two variables each. In this example, response messages contain eight variables, so four packets are sent.

The actual message received is shown in Table 43.

Table 43: Example CAN Response

Message	CAN SID	Value 1	Value 2
1	0x0502	fault_status_word_1	right_rear_vel_mps
2	0x0503	left_rear_vel_mps	rear_base_batt_2_soc
3	0x0504	mcu_0_inst_power_W	mcu_1_inst_power_W
4	0x0505	fram_dtz_decel_limit_mps2	0x0000, CRC

Table 42: RMP Response

Item	UDFB	Variable Name
Variable 1	UDFB1-bit0	fault_status_word_1
Variable 2	UDFB1-bit31	right_rear_vel_mps
Variable 3	UDFB2-bit0	left_rear_vel_mps
Variable 4	UDFB2-bit15	rear_base_batt_2_soc
Variable 5	UDFB3-bit4	mcu_0_inst_power_W
Variable 6	UDFB3-bit5	mcu_1_inst_power_W
Variable 7	UDFB3-bit15	fram_dtz_decel_limit_mps2
Variable 8	—	0x0000, CRC

RMP Response (cont.)

USB and UDP Response Structure

USB and UDP responses are a byte array representing the array of 32-bit response values plus the CRC-16. All values are 32-bits.

Each value can be decoded as:

$$\begin{aligned} \text{Value}[i] = & \text{U32_T} ((\text{byte}[i \times 4] \ll 24) \quad \& \text{0xFF000000}) | \\ & ((\text{byte}[i \times 4 + 1] \ll 16) \quad \& \text{0x00FF0000}) | \\ & ((\text{byte}[i \times 4 + 2] \ll 8) \quad \& \text{0x0000FF00}) | \\ & (\text{byte}[i \times 4 + 3] \quad \& \text{0x000000FF}); \end{aligned}$$

Where *i* is the index of the value in the response array. The response array will always contain the number of 32-bit values specified by the UDFBs and a CRC-16.

Example

Set the UDFBs as shown below. This is the same configuration as in the example for "CAN Response Structure," p. 58.

- UDFB1 = 0x80000001 (bits 0, 31)
- UDFB2 = 0x00008001 (bits 0, 15)
- UDFB3 = 0x00008030 (bits 4-5, 15)
- UDFB4 = 0x00000000 (none)

After the UDFBs are set, all RMP response messages will contain the following variables:

[UDFB1-bit0, UDFB1-bit31, UDFB2-bit0, UDFB2-bit15, UDFB3-bit4, UDFB3-bit5, UDFB3-bit15, CRC-16]

Or with variable names from the UDFB tables:

[fault_status_word_1, right_rear_vel_mps, left_rear_vel_mps, rear_base_batt_2_soc, mcu_0_inst_power_W, mcu_1_inst_power_W, fram_dtz_decel_limit_mps2, CRC-16]

USB and UDP response messages are composed of one large packet containing all the variables.

The actual message received is shown in Table 45.

Table 44: RMP Response

Item	UDFB	Variable Name
Variable 1	UDFB1-bit0	fault_status_word_1
Variable 2	UDFB1-bit31	right_rear_vel_mps
Variable 3	UDFB2-bit0	left_rear_vel_mps
Variable 4	UDFB2-bit15	rear_base_batt_2_soc
Variable 5	UDFB3-bit4	mcu_0_inst_power_W
Variable 6	UDFB3-bit5	mcu_1_inst_power_W
Variable 7	UDFB3-bit15	fram_dtz_decel_limit_mps2
Variable 8	—	0x0000, CRC-16

Table 45: USB and UDP Omni Motion Commands

Data Byte	Item	Description
Data[0] – Data[1]	Message ID	0x0502
Data[2] – Data[5]	Variable 1	fault_status_word_1
Data[6] – Data[9]	Variable 2	right_rear_vel_mps
Data[10] – Data[13]	Variable 3	left_rear_vel_mps
Data[14] – Data[17]	Variable 4	rear_base_batt_2_soc
Data[18] – Data[21]	Variable 5	mcu_0_inst_power_W
Data[22] – Data[25]	Variable 6	mcu_1_inst_power_W
Data[26] – Data[29]	Variable 7	fram_dtz_decel_limit_mps2
Data[30] – Data[31]	Variable 8	Data[30] – Data[31]: 0x0000 Data[32] – Data[33]: CRC-16

RMP Response (cont.)

User Defined Feedback Bitmap 1

The following table describes the variables defined by each bit in UDFB1. The masks associated with UDFB1 for ease of implementing a parsing algorithm are:

FLOATING_POINT_MASK = 0xFF7FF900
 INTEGER_MASK = 0x008006FF

Table 46: User Defined Feedback Bitmap 1

Bit Value	Variable Name	Format	Unit	Description
0x00000001	fault_status_word_1	U32_T	Unitless	Fault status word 1
0x00000002	fault_status_word_2	U32_T	Unitless	Fault status word 2
0x00000004	fault_status_word_3	U32_T	Unitless	Fault status word 3
0x00000008	fault_status_word_4	U32_T	Unitless	Fault status word 4
0x00000010	mcu_0_fault_status	U32_T	Unitless	MCU 0 internal fault status
0x00000020	mcu_1_fault_status ¹	U32_T	Unitless	MCU 1 internal fault status
0x00000040	mcu_2_fault_status ¹	U32_T	Unitless	MCU 2 internal fault status
0x00000080	mcu_3_fault_status ¹	U32_T	Unitless	MCU 3 internal fault status
0x00000100	frame_count	Float32	Seconds	The operational runtime in seconds since the last power on
0x00000200	operational_state	U32_T	Unitless	CCU Init: 0 Init Propulsion: 1 Check_Startup_Issues: 2 Standby Mode: 3 Tractor Mode: 4 Disable Power: 5
0x00000400	dynamic_response	U32_T	Unitless	No Response: 0x00000000 Zero Speed: 0x00000002 Limit Speed: 0x00000004 Decel to Zero: 0x00000008 Disable MCU0: 0x00000100 Disable MCU1: 0x00000200 Disable MCU2: 0x00000400 Disable MCU3: 0x00000800 Disable Response: 0x00001000
0x00000800	min_propulsion_batt_soc	Float32	Percentage	The minimum of all propulsion battery states of charge
0x00001000	aux_batt_soc	Float32	Percentage	The auxiliary battery state of charge
0x00002000	inertial_x_acc_g ²	Float32	g	The raw x axis acceleration
0x00004000	inertial_y_acc_g ²	Float32	g	The raw y axis acceleration
0x00008000	inertial_x_rate_rps ²	Float32	rad/s	The raw x rotational rate
0x00010000	inertial_y_rate_rps ²	Float32	rad/s	The raw y rotational rate
0x00020000	inertial_z_rate_rps ²	Float32	rad/s	The raw z rotational rate
0x00040000	pse_pitch_deg ²	Float32	deg	The estimated inertial pitch angle
0x00080000	pse_pitch_rate_dps ²	Float32	deg/s	The estimated inertial pitch rate
0x00100000	pse_roll_deg ²	Float32	deg	The estimated inertial roll angle
0x00200000	pse_roll_rate_dps ²	Float32	deg/s	The estimated inertial roll rate
0x00400000	pse_yaw_rate_dps ²	Float32	deg/s	The estimated inertial yaw rate

RMP Response (cont.)

Table 46: User Defined Feedback Bitmap 1 (cont.)

Bit Value	Variable Name	Format	Unit	Description
0x00800000	pse_data_is_valid ²	U32_T	Unitless	This is a bitmap of valide PSE data. There are two PSEs running on the CCU: one for each redundant side of the BSA. If the value is zero, PSE data should be discarded. No_PSE_valid: 0x00000000 PSE1_valid: 0x00000001 PSE2:valid: 0x00000002
0x01000000	yaw_rate_limit_rps	Float32	rad/s	The machine yaw rate limit, including internal limits set by the Safety Kernel
0x02000000	vel_limit_mps	Float32	m/s	The machine velocity limit, including internal limits set by the Safety Kernel
0x04000000	linear_accel_msp2	Float32	m/s ²	Linear acceleration derived from wheel velocities
0x08000000	linear_vel_mps	Float32	m/s	Linear velocity of the RMP
0x10000000	differential_wheel_vel_rps	Float32	rad/s	Differential wheel speed (yaw rate) of the RMP derived using wheel velocities
0x20000000	right_front_vel_mps	Float32	m/s	Right front wheel velocity
0x40000000	left_front_vel_mps	Float32	m/s	Left front wheel velocity
0x80000000	right_rear_vel_mps	Float32	m/s	Right rear wheel velocity

¹ Note that the MCU data available is dependent on the number of MCUs in the RMP.

² Note that the availability of inertial data is dependent on a BSA being present in the RMP. If your system does not have a BSA, this data will be set to zero. BSA upgrades are available from Segway Inc.

RMP Response (cont.)

User Defined Feedback Bitmap 2

The following table describes the variables defined by each bit in UDFB2. The masks associated with UDFB2 for ease of implementing a parsing algorithm are:

FLOATING_POINT_MASK = 0x3FFFFFFF
 INTEGER_MASK = 0xC0000000

Table 47: User Defined Feedback Bitmap 2

Bit Value	Variable Name	Format	Unit	Description
0x00000001	left_rear_vel_mps	Float32	m/s	Left rear wheel velocity
0x00000002	right_front_pos_m	Float32	m	Right front wheel linear displacement
0x00000004	left_front_pos_m	Float32	m	Left front wheel linear displacement
0x00000008	right_rear_pos_m ¹	Float32	m	Right rear wheel linear displacement
0x00000010	left_rear_pos_m ¹	Float32	m	Left rear wheel linear displacement
0x00000020	linear_pos_m	Float32	m	RMP linear displacement
0x00000040	right_front_current_A0pk	Float32	A (0-peak)	Total right front motor current
0x00000080	left_front_current_A0pk	Float32	A (0-peak)	Total left front motor current
0x00000100	right_rear_current_A0pk ¹	Float32	A (0-peak)	Total right rear motor current
0x00000200	left_rear_current_A0pk ¹	Float32	A (0-peak)	Total left rear motor current
0x00000400	max_motor_current_A0pk	Float32	A (0-peak)	Maximum motor current of all motors
0x00000800	right_front_current_limit_A0pk	Float32	A (0-peak)	Minimum right front motor current limit (each motor is redundant)
0x00001000	left_front_currrent_limit_A0pk	Float32	A (0-peak)	Minimum left front motor current limit (each motor is redundant)
0x00002000	right_rear_current_limit_A0pk ¹	Float32	A (0-peak)	Minimum right rear motor current limit (each motor is redundant)
0x00004000	left_rear_current_limit_A0pk ¹	Float32	A (0-peak)	Minimum left rear motor current limit (each motor is redundant)
0x00008000	min_motor_current_limit_A0pk	Float32	A (0-peak)	Minimum motor current limit of all motors
0x00010000	front_base_batt_1_soc	Float32	Percentage	Front powerbase front battery state of charge
0x00020000	front_base_batt_2_soc ²	Float32	Percentage	Front powerbase rear battery state of charge
0x00040000	rear_base_batt_1_soc ¹	Float32	Percentage	Rear powerbase front battery state of charge
0x00080000	rear_base_batt_2_soc ¹	Float32	Percentage	Rear powerbase rear battery state of charge
0x00100000	front_base_batt_1_temp_degC	Float32	°C	Front powerbase front battery temperature
0x00200000	front_base_batt_2_temp_degC ²	Float32	°C	Front powerbase rear battery temperature
0x00400000	rear_base_batt_1_temp_degC ¹	Float32	°C	Rear powerbase front battery temperature
0x00800000	rear_base_batt_2_temp_degC ¹	Float32	°C	Rear powerbase rear battery temperature
0x01000000	vel_target_mps	Float32	m/s	Velocity controller target
0x02000000	yaw_rate_target_rps	Float32	rad/s	Yaw controller target

RMP Response (cont.)

Table 47: User Defined Feedback Bitmap 2 (cont.)

Bit Value	Variable Name	Format	Unit	Description
0x04000000	angle_target_deg ³	Float32	Degrees	Angle target (for omni platforms)
0x80000000	aux_batt_voltage_V ⁴	Float32	VDC	Auxiliary battery voltage
0x10000000	aux_batt_current_A ⁴	Float32	A (0-peak)	Auxiliary battery current
0x20000000	aux_batt_temp_degC ⁴	Float32	°C	Auxiliary battery temperature
0x40000000	abb_system_status ⁴	U32_T	Unitless	ABB system status
0x80000000	aux_batt_status ⁴	U32_T	Unitless	ABB battery status

¹ Note that the motor data available is dependent on the number of powerbases in the system. This also pertains to propulsion battery data. If there is only one powerbase, only the "front" powerbase data will be available; all other powerbase data will be set to zero.

² Note that on single powerbase machines with only one MCU, the front powerbase rear battery does not exist; therefore the data is set to zero.

³ Only valid on Omni platforms.

⁴ Note that on systems without an ABB this data is set to zero.

RMP Response (cont.)

User Defined Feedback Bitmap 3

The following table describes the variables defined by each bit in UDFB3. The masks associated with UDFB3 for ease of implementing a parsing algorithm are:

FLOATING_POINT_MASK = 0x1FE4700F
 INTEGER_MASK = 0x001B8FF0

Table 48: User Defined Feedback Bitmap 3

Bit Value	Variable Name	Format	Unit	Description
0x00000001	aux_batt_faults ¹	U32_T	Unitless	ABB battery faults
0x00000002	7p2V_battery_voltage ²	Float32	VDC	CCU 7.2V measured pack voltage
0x00000004	sp_sw_build_id	U32_T	int	The Segway Processor Build ID
0x00000008	uip_sw_build_id	U32_T	int	The User Interface Processor Build ID
0x00000010	mcu_0_inst_power_W ¹	Float32	Watts	Instantaneous power consumed by MCU0
0x00000020	mcu_1_inst_power_W ¹	Float32	Watts	Instantaneous power consumed by MCU1
0x00000040	mcu_2_inst_power_W ¹	Float32	Watts	Instantaneous power consumed by MCU2
0x00000080	mcu_3_inst_power_W ¹	Float32	Watts	Instantaneous power consumed by MCU3
0x00000100	mcu_0_total_energy_Wh ¹	Float32	Watt-hours	Total energy consumed by MCU0 ³
0x00000200	mcu_1_total_energy_Wh ¹	Float32	Watt-hours	Total energy consumed by MCU1 ³
0x00000400	mcu_2_total_energy_Wh ¹	Float32	Watt-hours	Total energy consumed by MCU2 ³
0x00000800	mcu_3_total_energy_Wh ¹	Float32	Watt-hours	Total energy consumed by MCU3 ³
0x00001000	fram_vel_limit_mps	Float32	m/s	User velocity limit stored in NVM (RMP_CMD_SET_MAXIMUM_VELOCITY)
0x00002000	fram_accel_limit_mps2	Float32	m/s ²	User acceleration limit stored in NVM (RMP_CMD_SET_MAXIMUM_ACCELERATION)
0x00004000	fram_decel_limit_mps2	Float32	m/s ²	User defined deceleration limit stored in NVM (RMP_CMD_SET_MAXIMUM_DECELERATION)
0x00008000	frame_dtz_decel_limit_mps2	Float32	m/s ²	User defined DTZ decel limit stored in NVM (RMP_CMD_SET_MAXIMUM_DTZ_DECEL_RATE)
0x00010000	fram_coastdown_decel_mps2	Float32	m/s ²	Acceleration-based mapping coastdown acceleration stored in NVM (RMP_CMD_SET_COASTDOWN_ACCEL)
0x00020000	fram_yaw_rate_limit_rps	Float32	rad/s	User defined yaw rate limit stored in NVM (RMP_CMD_SET_MAXIMUM_TURN_RATE)
0x00040000	fram_yaw_accel_limit_rps2	Float32	rad/s ²	User yaw acceleration limit stored in NVM (RMP_CMD_SET_MAXIMUM_TURN_ACCEL)
0x00080000	fram_tire_diameter_m	Float32	m	RMP tire diameter stored in NVM (RMP_CMD_SET_TIRE_DIAMETER)
0x00100000	fram_wheel_base_length_m	Float32	m	RMP wheel base length stored in NVM (RMP_CMD_SET_WHEEL_BASE_LENGTH)
0x00200000	fram_wheel_track_width_m	Float32	m	RMP track width (lateral distance between tires) stored in NVM (RMP_CMD_SET_WHEEL_TRACK_WIDTH)
0x00400000	fram_transmission_ratio	Float32	Unitless ratio	RMP transmission (gearbox) ratio stored in NVM (RMP_CMD_SET_TRANSMISSION_RATIO)
0x00800000	fram_config_bitmap	U32_T	Unitless	Input mapping and audio silence configuration bitmap stored in NVM (RMP_CMD_SET_INPUT_CONFIG_BITMAP)

RMP Response (cont.)

Table 48: User Defined Feedback Bitmap 3 (cont.)

Bit Value	Variable Name	Format	Unit	Description
0x01000000	fram_eth_ip_address	U32_T	Unitless	RMP Ethernet IP address stored in NVM (RMP_CMD_SET_ETH_IP_ADDRESS)
0x02000000	fram_eth_port_number	U32_T	Unitless	RMP Ethernet port number stored in NVM (RMP_CMD_SET_ETH_PORT_NUMBER)
0x04000000	fram_eth_subnet_mask	U32_T	Unitless	RMP Ethernet subnet mask stored in NVM (RMP_CMD_SET_ETH_SUBNET_MASK)
0x08000000	fram_eth_gateway	U32_T	Unitless	RMP Ethernet gateway stored in NVM (RMP_CMD_SET_ETH_GATEWAY)
0x10000000	user_feedback_bitmap_1	U32_T	Unitless	User Defined Feedback Bitmap 1 stored in NVM (RMP_CMD_SET_USER_FB_1_BITMAP)
0x20000000	user_feedback_bitmap_2	U32_T	Unitless	User Defined Feedback Bitmap 2 stored in NVM (RMP_CMD_SET_USER_FB_2_BITMAP)
0x40000000	user_feedback_bitmap_3	U32_T	Unitless	User Defined Feedback Bitmap 3 stored in NVM (RMP_CMD_SET_USER_FB_3_BITMAP)
0x80000000	user_feedback_bitmap_4	U32_T	Unitless	User Defined Feedback Bitmap 4 stored in NVM (RMP_CMD_SET_USER_FB_4_BITMAP)

¹ Note that on systems without an ABB this data is set to zero.

² Note that on systems without a 7.2 V battery this data is set to zero.

³ Since power on.

RMP Response (cont.)

User Defined Feedback Bitmap 4

UDFB4 is for future expansion and therefore contains no valid bits. The masks associated with UDFB4 for ease of implementing a parsing algorithm are:

FLOATING_POINT_MASK = 0x00000000

INTEGER_MASK = 0x00000000

IEEE754 32-bit Floating Point and Integer Representation

For background on the IEEE754 standard see http://en.wikipedia.org/wiki/IEEE_754-2008.

For a 32-bit CPU or Microprocessor that conforms to the IEEE754 format, the following functions would be used to convert back and forth between integer and floating point representation:

Where U32_T is a 32-bit unsigned integer and Float32 is a 32-bit single precision floating point number.

```
//-----
//          convert_float32_to_u32
//
// \brief   Converts a Float32 value to U32_T in the same bit pattern
//
// \param   Float32 to be converted
//
// \return  Converted value
//
//-----
U32_T convert_float32_to_u32(Float32 value)
{
    //
    // Convert the pointer to the Float value to a U32_T pointer
    // and return the dereferenced value.
    //
    //lint -save -e740
    return *((U32_T*)&value);
    //lint -restore
}

//-----
//          convert_u32_to_float32
//
// \brief   Converts a U32_T value to Float32 in the same bit pattern
//
// \param   U32_T to be converted
//
// \return  Converted value
//
//-----
Float32 convert_u32_to_float32(U32_T value)
{
    //
    // Convert the pointer to the Float value to a U32_T pointer
    // and return the dereferenced value.
    //
    //lint -save -e740
    return *((Float32*)&value);
    //lint -restore
}
```

Cyclic Redundancy Check (CRC)-16

For information about CRC calculations see http://en.wikipedia.org/wiki/Cyclic_redundancy_check.

```
//-----
//COPYRIGHT © 2011 SEGWAY Inc.
//
//Contains confidential and proprietary information which may not be copied,
//disclosed or used by others except as expressly authorized in writing
//by SEGWAY, Inc.
//
// \file   tk_crc.c
//
// \brief  This module contains basic functions for data transfer level
//         error checking
//
// \platform RMP Auxiliary Battery Board
//
//-----
#include "defines.h"
#include "tk_crc.h"
#include "types.h"

//
// CRC table defines
//
#define CRC_ADJUSTMENT 0xA001
#define CRC_TABLE_SIZE 256
#define INITIAL_CRC (0)

//
// The CRC table
//
static U16_T crc_table[CRC_TABLE_SIZE];

//
// Private function prototypes
//
static U16_T compute_crc_table_value(U16_T the_byte);
//-----
//
//         tk_crc_initialize
//
// \brief  Initialize the crc table
//
// \param  void
//
// \return void
//
//-----
void tk_crc_initialize(void)
{
    U16_T byte;

    for(byte = 0; byte < CRC_TABLE_SIZE; byte++)
    {
        crc_table[byte] = compute_crc_table_value(byte);
    }
}

//-----
//
//         tk_crc_calculate_crc_16
//
// \brief  This computes an updated CRC 16 given the current value of
```

Cyclic Redundancy Check (CRC)-16 (cont.)

```

//          the CRC 16 and a new data byte.
//
// \param   old_crc: the CRC from the last calculation
//          new_byte: the new byte to add to the CRC calculation
//
// \return  U16_T the new CRC
//
//-----
U16_T tk_crc_calculate_crc_16(U16_T old_crc, U8_T new_byte)
{
    U16_T temp;
    U16_T new_crc;

    temp = old_crc ^ new_byte;

    new_crc = (old_crc >> 8) ^ crc_table[temp & 0x00FF];

    return (new_crc);
}

//-----
//          tk_crc_compute_byte_buffer_crc
//
// \brief   This function computes the CRC-16 value for the passed in
//          buffer. The newly computed CRC is saved into the last
//          2 spots in the byte buffer.
//
// \param   *byte_buffer: pointer to the byte buffer which we want to CRC
//          bytes_in_buffer: number of bytes in the buffer
//
// \return  void
//
//-----
void tk_crc_compute_byte_buffer_crc(U8_T *byte_buffer, U32_T bytes_in_buffer)
{
    U32_T count;
    U32_T crc_index = bytes_in_buffer - 2;
    U16_T new_crc = INITIAL_CRC;

    //
    // We'll loop through each word of the message and update
    // the CRC. Start with the value chosen for CRC initialization.
    //
    for(count = 0; count < crc_index; count++)
    {
        //
        // Now we'll send each byte to the CRC calculation.
        //
        new_crc = tk_crc_calculate_crc_16(new_crc, byte_buffer[count]);
    }

    //
    // The new CRC is saved in the last word.
    //
    byte_buffer[crc_index] = (U8_T)((new_crc & 0xFF00) >> 8);

    byte_buffer[crc_index+1] = (U8_T)(new_crc & 0x00FF);
}

//-----
//          tk_crc_byte_buffer_crc_is_valid

```

Cyclic Redundancy Check (CRC)-16 (cont.)

```

//
// \brief      This function computes the CRC-16 value for the passed in
//              buffer. This new CRC is compared to the last value stored
//              in the buffer (which is assumed to be the CRC-16 for the
//              buffer).
//
// \param      *byte_buffer: pointer to the byte buffer which we want check the
//              CRC
//              bytes_in_buffer: number of bytes in the buffer
//
// \return     TRUE if CRC is valid; FALSE otherwise
//
//-----
BOOLEAN_T tk_crc_byte_buffer_crc_is_valid(U8_T *byte_buffer, U32_T bytes_in_buffer)
{
    U32_T count;
    U32_T crc_index = bytes_in_buffer - 2;
    U16_T new_crc = INITIAL_CRC;
    U16_T received_crc = INITIAL_CRC;
    BOOLEAN_T success;

    //
    // We'll loop through each word of the message and update
    // the CRC. Start with the value chosen for CRC initialization.
    //
    for(count = 0; count < crc_index; count++)
    {
        new_crc = tk_crc_calculate_crc_16(new_crc, byte_buffer[count]);
    }

    //
    // The new CRC is checked against that stored in the buffer.
    //
    received_crc = ((byte_buffer[crc_index] << 8) & 0xFF00);
    received_crc |= (byte_buffer[crc_index+1] & 0x00FF);

    if (received_crc == new_crc)
    {
        success = TRUE;
    }
    else
    {
        success = FALSE;
    }

    return (success);
}

//-----
//              compute_crc_table_value
//
// \brief      computes the table value for a given byte
//
// \param      the_byte: the byte index in the table
//
// \return     void
//
//-----
static U16_T compute_crc_table_value(U16_T the_byte)
{
    U16_T j;
    U16_T k;

```

Cyclic Redundancy Check (CRC)-16 (cont.)

```
U16_T table_value;

k = the_byte;
table_value = 0;
for(j = 0; j < 8; j++)
{
    if (((table_value ^ k) & 0x0001) == 0x0001)
    {
        table_value = (table_value >> 1) ^ CRC_ADJUSTMENT;
    }
    else
    {
        table_value >>= 1;
    }

    k >>= 1;
}
return (table_value);
}
```

Fault Status Definitions

```
""-----
```

RMP Fault definitions

This section is used to define the decoding of fault status words sent by the RMP. The meaning of specific faults can be found in the interface guide.

```
-----""
```

```
NO_FAULT                = 0x00000000
ALL_FAULTS              = 0xFFFFFFFF
```

```
""
```

Transient faults: These faults are not latching and can be asserted and then cleared during runtime. There are currently no transient faults for the RMP

```
""
```

```
transient_fault_decode = dict({
    0x00000000: ""});
```

```
""
```

Critical faults: These faults are latching.

```
""
```

```
critical_fault_decode = dict({
    0x00000000: "",
    0x00000001: "CRITICAL_FAULT_INIT",
    0x00000002: "CRITICAL_FAULT_INIT_UIP_COMM",
    0x00000004: "CRITICAL_FAULT_INIT_PROPULSION",
    0x00000008: "CRITICAL_FAULT_INIT_TIMEOUT",
    0x00000010: "CRITICAL_FAULT_FORW_SPEED_LIMITER_HAZARD",
    0x00000020: "CRITICAL_FAULT_AFT_SPEED_LIMITER_HAZARD",
    0x00000040: "CRITICAL_FAULT_CHECK_STARTUP",
    0x00000080: "CRITICAL_FAULT_APP_VELOCITY_CTL_FAILED",
    0x00000100: "CRITICAL_FAULT_APP_POSITION_CTL_FAILED",
    0x00000200: "CRITICAL_FAULT_ABB_SHUTDOWN",
    0x00000400: "CRITICAL_FAULT_AP_MODE_TRANS_TIMEOUT",
    0x00000800: "CRITICAL_FAULT_PITCH_ANGLE_EXCEEDED",
    0x00001000: "CRITICAL_FAULT_ROLL_ANGLE_EXCEEDED"})
```

Fault Status Definitions (cont.)

"""

Communication faults: These faults are latching.

"""

```
comm_fault_decode = dict({
    0x00000000: "",
    0x00000001: "COMM_FAULT_UIP_MISSING_UIP_DATA",
    0x00000002: "COMM_FAULT_UIP_UNKNOWN_MESSAGE_RECEIVED",
    0x00000004: "COMM_FAULT_UIP_BAD_CHECKSUM",
    0x00000008: "COMM_FAULT_UIP_TRANSMIT",
    0x00000010: "COMM_FAULT_UI_BAD_MOTION_CMD",
    0x00000020: "COMM_FAULT_UI_UNKOWN_CMD",
    0x00000040: "COMM_FAULT_UI_BAD_PACKET_CHECKSUM"})
```

"""

MCU faults: These faults are latching.

"""

```
mcu_fault_decode = dict({
    0x00000000: "",
    0x00000001: "MCU_FAULT_MCU_0_IS_DEGRADED",
    0x00000002: "MCU_FAULT_MCU_0_IS_FAILED",
    0x00000004: "MCU_FAULT_MCU_0_REQUESTS_REDUCED_PERFORMANCE",
    0x00000008: "MCU_FAULT_MCU_0_REQUESTS_ZERO_SPEED",
    0x00000010: "MCU_FAULT_MCU_1_IS_DEGRADED",
    0x00000020: "MCU_FAULT_MCU_1_IS_FAILED",
    0x00000040: "MCU_FAULT_MCU_1_REQUESTS_REDUCED_PERFORMANCE",
    0x00000080: "MCU_FAULT_MCU_1_REQUESTS_ZERO_SPEED",
    0x00000100: "MCU_FAULT_MCU_2_IS_DEGRADED",
    0x00000200: "MCU_FAULT_MCU_2_IS_FAILED",
    0x00000400: "MCU_FAULT_MCU_2_REQUESTS_REDUCED_PERFORMANCE",
    0x00000800: "MCU_FAULT_MCU_2_REQUESTS_ZERO_SPEED",
    0x00001000: "MCU_FAULT_MCU_3_IS_DEGRADED",
    0x00002000: "MCU_FAULT_MCU_3_IS_FAILED",
    0x00004000: "MCU_FAULT_MCU_3_REQUESTS_REDUCED_PERFORMANCE",
    0x00008000: "MCU_FAULT_MCU_3_REQUESTS_ZERO_SPEED",
    0x00010000: "MCU_FAULT_MISSING_MCU_0_DATA",
    0x00020000: "MCU_FAULT_MISSING_MCU_1_DATA",
    0x00040000: "MCU_FAULT_MISSING_MCU_2_DATA",
    0x00080000: "MCU_FAULT_MISSING_MCU_3_DATA",
    0x00100000: "MCU_FAULT_UNKNOWN_MESSAGE_RECEIVED"})
```

Fault Status Definitions (cont.)

"""

Define a mask to indicate that the CCU has detected the fault and not the MCU

"""

```
CCU_DETECTED_MCU_FAULT_MASK = 0x001F0000
```

"""

Sensor faults: These faults are latching.

"""

```
sensor_fault_decode = dict({
    0x00000000: "",
    0x00000001: "SENSOR_FAULT_2P5V_VREF_RANGE_FAULT",
    0x00000002: "SENSOR_FAULT_7P2V_VBAT_RANGE_FAULT",
    0x00000004: "SENSOR_FAULT_7P2V_VBAT_WARNING",
    0x00000008: "SENSOR_FAULT_7P2V_BATT_INBALANCE_FAULT",
    0x00000010: "SENSOR_FAULT_7P2V_BATT_TEMPERATURE_FAULT",
    0x00000020: "SENSOR_FAULT_DIGITAL_INPUT",
    0x00000040: "SENSOR_FAULT_RANGE",
    0x00000080: "SENSOR_FAULT_DEFAULT",
    0x00000100: "SENSOR_FAULT_5V_MONITOR_RANGE_FAULT",
    0x00000200: "SENSOR_FAULT_12V_MONITOR_RANGE_FAULT"})
```

"""

BSA faults: These faults are latching.

"""

```
bsa_fault_decode = dict({
    0x00000000: "",
    0x00000001: "BSA_FAULT_SIDE_A_MISSING_BSA_DATA",
    0x00000002: "BSA_FAULT_SIDE_B_MISSING_BSA_DATA",
    0x00000004: "BSA_FAULT_UNKNOWN_MESSAGE_RECEIVED",
    0x00000008: "BSA_FAULT_TRANSMIT_A_FAILED",
    0x00000010: "BSA_FAULT_TRANSMIT_B_FAILED",
    0x00000020: "BSA_FAULT_DEFAULT",
    0x00000040: "BSA_FAULT_SIDE_A_RATE_SENSOR_SATURATED",
    0x00000080: "BSA_FAULT_SIDE_B_RATE_SENSOR_SATURATED",
    0x00000100: "BSA_FAULT_SIDE_A_TILT_SENSOR_SATURATED",
    0x00000200: "BSA_FAULT_SIDE_B_TILT_SENSOR_SATURATED",
    0x00000400: "PSE_FAULT_COMPARISON"})
```

Fault Status Definitions (cont.)

"""

Architecture faults: These faults are latching.

"""

```
arch_fault_decode = dict({
    0x00000000: "",
    0x00000001: "ARCHITECT_FAULT_SPI_RECEIVE",
    0x00000002: "ARCHITECT_FAULT_SPI_TRANSMIT",
    0x00000004: "ARCHITECT_FAULT_SPI_RECEIVE_OVERRUN",
    0x00000008: "ARCHITECT_FAULT_SPI_RX_BUFFER_OVERRUN",
    0x00000010: "ARCHITECT_FAULT_COMMANDED_SAFETY_SHUTDOWN",
    0x00000020: "ARCHITECT_FAULT_COMMANDED_DISABLE",
    0x00000040: "ARCHITECT_FAULT_KILL_SWITCH_ACTIVE",
    0x00000080: "ARCHITECT_FAULT_FRAM_CONFIG_INIT_FAILED",
    0x00000100: "ARCHITECT_FAULT_FRAM_CONFIG_SET_FAILED",
    0x00000200: "ARCHITECT_FAULT_BAD_MODEL_IDENTIFIER",
    0x00000400: "ARCHITECT_FAULT_BAD_CCU_HW_REV",
    0x00000800: "ARCHITECT_FAULT_DECEL_SWITCH_ACTIVE"})
```

"""

Internal faults: These faults are latching.

"""

```
internal_fault_decode = dict({
    0x00000000: "",
    0x00000001: "INTERNAL_FAULT_HIT_DEFAULT_CONDITION",
    0x00000002: "INTERNAL_FAULT_HIT_SPECIAL_CASE"})
```

"""

MCU specific faults: These faults are detected locally by the MCU

"""

```
mcu_specific_fault_decode = dict({
    0x00000000: "",
    0x00000001: "MCU_TRANS_BATTERY_TEMP_WARNING",
    0x00000002: "MCU_TRANS_BATTERY_COLD_REGEN",
    0x00000004: "MCU_UNKNOWN",
    0x00000008: "MCU_UNKNOWN",
    0x00000010: "MCU_TRANS_LOW_BATTERY",
    0x00000020: "MCU_TRANS_BATT_OVERVOLTAGE",
    0x00000040: "MCU_CRITICAL_BATT_OVERVOLTAGE",
    0x00000080: "MCU_CRITICAL_EMPTY_BATTERY",
    0x00000100: "MCU_CRITICAL_BATTERY_TEMP",
```

Fault Status Definitions (cont.)

```

0x00000200: "MCU_COMM_CU_BCU_LINK_DOWN",
0x00000400: "MCU_COMM_INITIALIZATION_FAILED",
0x00000800: "MCU_COMM_FAILED_CAL_EEPROM",
0x00001000: "MCU_POWER_SUPPLY_TRANSIENT_FAULT",
0x00002000: "MCU_POWER_SUPPLY_12V_FAULT",
0x00004000: "MCU_POWER_SUPPLY_5V_FAULT",
0x00008000: "MCU_POWER_SUPPLY_3V_FAULT",
0x00010000: "MCU_JUNCTION_TEMP_FAULT",
0x00020000: "MCU_MOTOR_WINDING_TEMP_FAULT",
0x00040000: "MCU_MOTOR_DRIVE_FAULT",
0x00080000: "MCU_MOTOR_DRIVE_HALL_FAULT",
0x00100000: "MCU_MOTOR_DRIVE_AMP_FAULT",
0x00200000: "MCU_MOTOR_DRIVE_AMP_ENABLE_FAULT",
0x00400000: "MCU_MOTOR_DRIVE_AMP_OVERCURRENT_FAULT",
0x00800000: "MCU_MOTOR_DRIVE_VOLTAGE_FEEDBACK_FAULT",
0x01000000: "MCU_FRAME_FAULT",
0x02000000: "MCU_BATTERY_FAULT",
0x08000000: "MCU_MOTOR_STUCK_RELAY_FAULT",
0x10000000: "MCU_ACTUATOR_POWER_CONSISTENCY_FAULT",
0x20000000: "MCU_ACTUATOR_HALT_PROCESSOR_FAULT",
0x40000000: "MCU_ACTUATOR_DEGRADED_FAULT"}

```

""

All the fault groups are packed into four 32-bit fault status words. The following defines how they are packed into the words

""

""

Fault status word 0

""

```

FSW_ARCH_FAULTS_INDEX      = 0
FSW_ARCH_FAULTS_SHIFT      = 0
FSW_ARCH_FAULTS_MASK       = 0x00000FFF
FSW_CRITICAL_FAULTS_INDEX  = 0
FSW_CRITICAL_FAULTS_SHIFT  = 12
FSW_CRITICAL_FAULTS_MASK   = 0xFFFFF000

```

Fault Status Definitions (cont.)

""

Fault status word 1

""

```
FSW_COMM_FAULTS_INDEX      = 1
FSW_COMM_FAULTS_SHIFT      = 0
FSW_COMM_FAULTS_MASK       = 0x0000FFFF
FSW_INTERNAL_FAULTS_INDEX  = 1
FSW_INTERNAL_FAULTS_SHIFT  = 16
FSW_INTERNAL_FAULTS_MASK   = 0x000F0000
```

""

Fault status word 2

""

```
FSW_SENSORS_FAULTS_INDEX   = 2
FSW_SENSORS_FAULTS_SHIFT   = 0
FSW_SENSORS_FAULTS_MASK    = 0x0000FFFF
FSW_BSA_FAULTS_INDEX       = 2
FSW_BSA_FAULTS_SHIFT       = 16
FSW_BSA_FAULTS_MASK        = 0xFFFF0000
```

""

Fault status word 3

""

```
FSW_MCU_FAULTS_INDEX       = 3
FSW_MCU_FAULTS_SHIFT       = 0
FSW_MCU_FAULTS_MASK        = 0xFFFFFFFF
```

""

Fault group index definitions

""

```
FAULTGROUP_TRANSIENT      = 0;
FAULTGROUP_CRITICAL       = 1;
FAULTGROUP_COMM           = 2;
FAULTGROUP_SENSORS        = 3;
FAULTGROUP_BSA            = 4;
FAULTGROUP_MCU            = 5;
FAULTGROUP_ARCHITECTURE   = 6;
FAULTGROUP_INTERNAL       = 7;
NUM_OF_FAULTGROUPS       = 8;
```

Internal Connections

This section describes the hardware connections inside the Segway RMP enclosure. Some of these connections are used within the RMP for internal communication between components. Other connections are for external communication and can be used to control the RMP. Additional connections are for sending power between components.

Part numbers are supplied for Segway harnesses. Please reference the harness part number when ordering new harnesses.

Centralized Control Unit

The Segway RMP is designed to allow for the ultimate in flexibility and control over the platform. Part of this design is the Centralized Control Unit (CCU), which controls how the RMP functions and communicates.

The CCU has two processors on the board, each with a unique function and purpose. The Segway Processor controls the propulsion system, safety kernel, and other essential functions. The User Interface Processor controls the Auxiliary Battery Board and external communication interfaces.

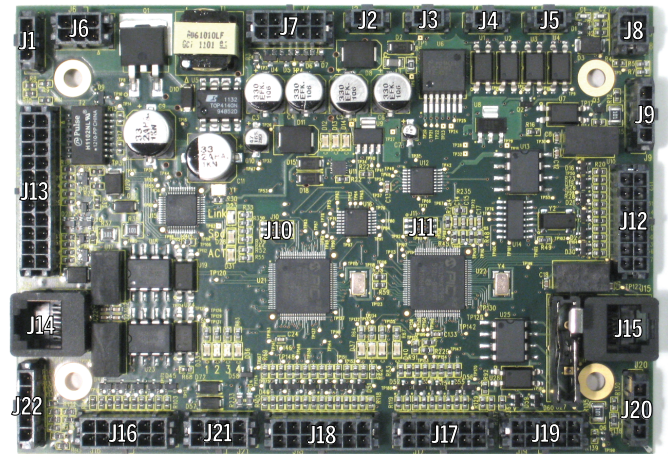

Figure 43: Centralized Control Unit

Table 49: CCU Connectors and Signals

Connector	Signal(s)	Harness	Destination(s)	Notes
J1	Boot1 / Boot2	23078-00002	Connector II	
J2	MCU Hardware Disable	–	–	
J3	MCU Hardware Disable	–	–	
J4	MCU Hardware Disable	23216-00001	Rear Powerbase	
J5	MCU Hardware Disable	23216-00001	Front Powerbase	
J6	72 VDC	–	–	Unused
J7	Hobby Radio	23072-00002	Connector I	
J8	Disable, DTZ	23078-00002	Connector II	
J9	CAN	23256-00001	Powerbases, Chargers	SP CAN Channel 1
J10	Debug Headers	–	–	Segway Use Only
J11	Debug Headers	–	–	Segway Use Only
J12	GPIO	–	–	Segway Use Only
J13	Ethernet, USB, CAN	23072-00002	Connector I, ABB J3	External Communication
J14	Programming	–	–	Segway Use Only
J15	Programming	–	–	Segway Use Only
J16	LEDs	23074-00002	Power LED, Status LED	
J17	Analog I/O	–	–	Segway Use Only
J18	Analog I/O	–	–	Segway Use Only
J19	Communication	–	–	Segway Use Only
J20	CAN	–	–	SP CAN Channel 2
J21	Power	23075-00002	12 V VAB	Power Connector
J22	7.2 VDC	22528-00002	7.2 V Battery	Power In

Auxiliary Battery Board

The Auxiliary Battery Board (ABB) communicates with the auxiliary battery, controls the Power Converters, and communicates with the CCU.

The ABB can operate either independently or in conjunction with a CCU.

NOTICE

- Incorrectly connecting power to the ABB can damage the board. Observe polarity on all inputs and outputs when connecting.
- Fuse is not replacable. If fuse blows, the board must be replaced.

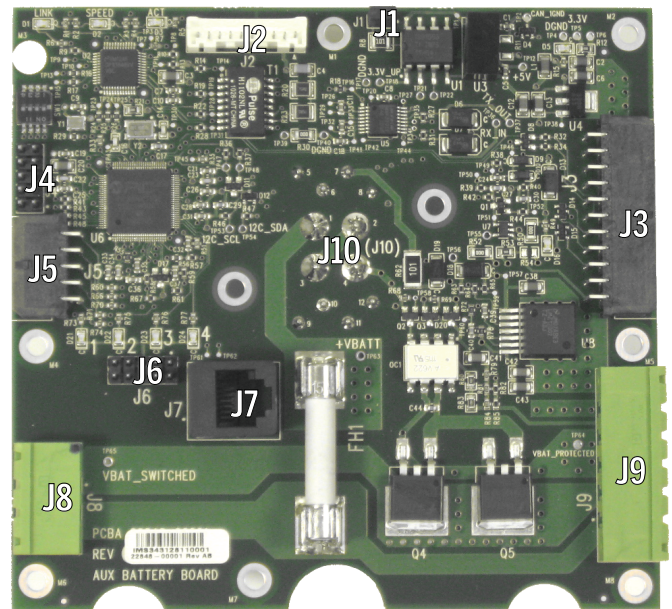

Figure 44: Auxiliary Battery Board

Table 50: ABB Connectors and Signals

Connector	Signal(s)	Harness	Destination(s)	Notes
J1	CAN Terminator	N/A	N/A	Jumper
J2	CAN, HV	21276-00002	Charger	Charger Input
J3	Ethernet, USB, CAN	23075-00002	12V VAB, CCU J13	Communication
J4	Debug Headers	–	–	Segway Use Only
J5	LEDs	–	–	
J6	Debug Headers	–	–	Segway Use Only
J7	Programming	–	–	Segway Use Only
J8	HV	23076-00001	Power Switch	
J9	HV	23075-00001	All VABs	Power Output
J10	Battery Connection	N/A	Battery (Back Side)	Battery Connection

Smart Charger Board

The Smart Charger Board (SCB) routes power from the External Power Supply to the internal components, including the powerbases and the ABB. It communicates with the powerbases and the ABB. It also controls the charge status LEDs.

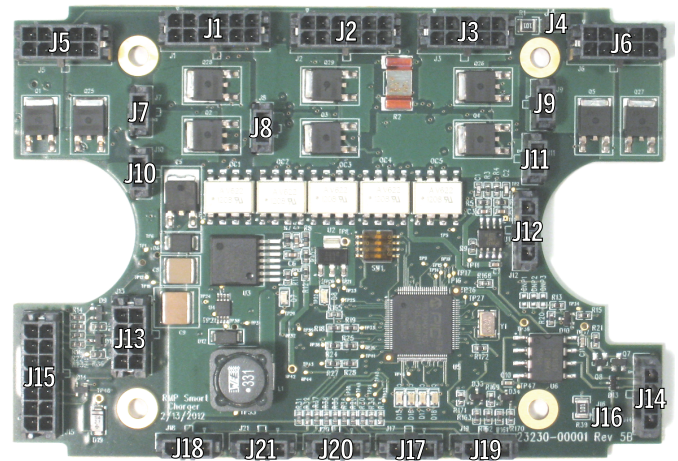

Figure 45: Smart Charger Board

Table 51: SCB Connectors and Signals

Connector	Signal(s)	Harness	Destination(s)	Notes
J1	CAN, HV	23216-00001	Rear Powerbase	HV Channel
J2	CAN, HV	23216-00001	Front Powerbase	HV Channel
J3	CAN, HV	23216-00001	Front Powerbase	HV Channel
J4	CAN Terminator	N/A	N/A	Jumper
J5	CAN, HV	23216-00001	Rear Powerbase	HV Channel
J6	CAN, HV	21276-00002	ABB J2	HV Channel
J7	HV	23214-00001	Connector IV	Charger Input
J8	HV	23214-00001	Connector IV	Charger Input
J9	HV	23214-00001	Connector IV	Charger Input
J10	HV	23214-00001	Connector IV	Charger Input
J11	HV	23214-00001	Connector IV	Charger Input
J12	CAN	23256-00001	Powerbases, CCU J9	CAN Channel 1
J13	I/O, Power	-	-	Expansion
J14	CAN	-	-	CAN Channel 1
J15	Communication	-	-	Segway Use Only
J16	CAN Terminator	N/A	N/A	Jumper
J17	LED	23320-00002	LED	Battery 1 Status
J18	LED	23320-00002	LED	Battery 3 Status
J19	LED	23320-00002	LED	Battery 0 Status
J20	LED	23320-00002	LED	Aux Battery Status
J21	LED	23320-00002	LED	Battery 2 Status

Communication

There are a variety of ways to communicate with the RMP inside the enclosure. Communication methods include CAN, USB, and Ethernet. There is also a hobby radio interface.

CAN

CAN channels utilize galvanic isolation hardware. This allows for CAN communication between systems in which the ground connection cannot be shared. The CCU has four CAN channels. The ABB has one CAN channel that communicates with the CCU.

- CAN channels utilize galvanic isolation hardware; ground must be connected.
- CAN channels have 120 Ohm terminator between CAN_High and CAN_Low.

User Interface Processor CAN 1

This CAN channel is primarily used for communication between the RMP and an outside source. This CAN channel is located at CCU J13.

Table 52: UIP CAN 1

J13 Pin	Name	Notes
13	CAN_High	
14	CAN_Low	
15	CAN_GND	Must be connected to CAN BUS GND.

User Interface Processor CAN 2

This CAN channel is primarily used for communication between the CCU and the ABB, if equipped. This CAN channel is located at CCU J13.

Table 53: UIP CAN 2

J13 Pin	Name	Notes
17	CAN_High	
18	CAN_Low	
19	CAN_GND	Must be connected to CAN BUS GND.

Segway Processor CAN 1

This CAN channel is strictly for Segway peripherals. This information is provided for completeness only. Please contact Segway if you believe you have a problem with this CAN channel. This CAN Channel is located at CCU J9.

Table 54: SP CAN 1

J9 Pin	Name	Notes
1	CAN_High	
2	CAN_Low	
3	CAN_GND	Must be connected to CAN BUS GND.

Segway Processor CAN 2

This CAN channel is reserved for future Segway peripherals. This information is provided for completeness only. Please contact Segway if you believe you have a problem with this CAN channel. This CAN channel is located at CCU J20.

Table 55: SP CAN 2

J20 Pin	Name	Notes
1	CAN_High	
2	CAN_Low	
3	CAN_GND	Must be connected to CAN BUS GND.

ABB CAN

The Auxiliary Battery Board (ABB) has one CAN channel, accessible from both J2 and J3. This CAN channel is used for communication between the ABB and the CCU. If using the ABB without a CCU this channel can be used to communicate directly with the ABB.

Table 56: ABB CAN

J2 Pin	J3 Pin	Name	Notes
4	5	CAN_High	
3	6	CAN_Low	
2 or 5	7	CAN_GND	Must be connected to CAN BUS GND.

USB

There is one user-accessible USB 2.0 compliant interface on the CCU. It can be connected to a standard computer and used as a communication interface. Windows drivers are supplied with the RMP Demo software (see "USB," p. 35).

CCU USB

This USB interface is primarily used for communication between the RMP and an outside source. This interface is located at CCU J13.

Table 57: CCU USB

J13 Pin	Name	USB Plug Pin #
7	USB_VBUS / VCC	1
8	USB_D+	2
9	USB_D-	3
22	GND	4
—	Shield Wire	Housing ¹

¹ The shield wire must be connectd to the housing of the USB plug and to the chassis of the RMP.

Ethernet

There is one 10 Mbps Ethernet interface on the CCU. For details on how to connect to the RMP over an Ethernet connection, see "Ethernet," p. 34.

CCU Ethernet

This Ethernet interface is primarily used for communication between the RMP and an outside source. This interface is located at CCU J13.

Table 58: CCU USB

J13 Pin	Name	RJ45 Pin #
1	ETH_TX+	1
2	ETH_TX-	2
3	ETH_RX+	3
4	ETH_RX-	6

Hobby Radio

⚠ WARNING!

Extreme care must be taken when setting the "safe" states on the Spektrum radio. The RMP could move in an uncontrolled way. This could cause, death, serious injury, or property damage.

The CCU allows for the connection of a remote control hobby radio for the purpose of demonstrating the platform in a closed environment. Due to the nature of the hobby radio protocol and the lack of deterministic error detection, the hobby radio input has the ability to create un-commanded motion by the RMP. For example, a user could set the "safe" state on their radio to the equivalent of full speed ahead; if communication with the radio is lost the RMP will go full speed ahead even if though this may not be the desired result.

The hobby radio input is compatible with Spektrum 6-channel air receivers. The input from each channel of the hobby radio is combined together using diode-OR logic to create one signal which is measured and decoded by the user interface processor. For this reason it does not matter in what order the channels are connected, as long as all 6 channels are connected.

This interface is located at CCU J7 and on Connector I (see "Connector I," p. 30).

Table 59: CCU Hobby Radio

J7 Pin	Name
1	+5 V out to receiver.
2-7	PWM radio control signals.
10	DGND (connect to receiver ground).

Table 60: Connector I Hobby Radio

Con. I Pin	Name
k	RADIO1
L	RADIO2
m	RADIO3
M	RADIO4
N	RADIO5
n	RADIO6
P	RADIO_GND
K	RADIO+5V

The hobby radio interface has only been tested with a Spektrum AR6115 receiver and a Spektrum DX6i transmitter. Other models are not guaranteed to work.

Be aware that the location of the receiver will affect its ability to receive radio signals. Placing the receiver on the side of the RMP may create one or more blind spots. Placing the receiver inside the enclosure may block it from receiving any signals at all.

Hobby Radio Configuration

Follow this procedure to configure a Spektrum hobby radio for use with the RMP.

WARNING!

Extreme care must be taken when setting the "safe" states on the Spektrum radio. The RMP could move in an uncontrolled way. To avoid death, serious injury, or property damage, raise the RMP so the wheels are off the ground before proceeding to configure the hobby radio. Avoid contact with the wheels while they are spinning.

These instructions assume that you are familiar with using the hobby radio. For more detailed instructions please refer to the manufacturer's documentation for your hobby radio.

1. Raise the RMP so the wheels are off the ground. This will prevent the RMP from moving unexpectedly while configuring the hobby radio.
2. On the transmitter, create a new model with the following attributes:
 - a. Go to the Setup List:
 - i. Model Type: ACRO
 - ii. Model Name: RMP
 - iii. Reverse: Ailerons Reversed
 - b. Go to the Adjust List, select Flaps, and set the following settings:
 - i. Norm: 0
 - ii. Land: ▼100
3. Bind the transmitter and receiver.
 - a. Prepare the transmitter.
 - i. Set all switches to 0.
 - ii. Lower the throttle (left joystick) to the lowest position.
 - iii. Make sure the transmitter is powered off.
 - b. Prepare the receiver.
 - i. Insert the bind plug into the BATT/BIND receptacle.
 - ii. Connect 5V DC power to the receiver.
 - iii. The receiver's LED flashes when the receiver is ready to bind.
 - c. Bind.
 - i. While holding the Trainer switch, power on the transmitter.
 - ii. Keep holding the trainer switch until the receiver's LED stays illuminated; this indicates the receiver is bound to the transmitter.
 - d. Finish.
 - i. Remove the bind plug from the receiver.
4. Connect to the RMP.
 - a. Connect the receiver to the RMP (see Table 59 and Table 60).
 - b. Flip the Gear switch on the transmitter to 1. This will prevent the RMP from immediately shutting down once the radio connection is established.
 - c. Turn on the transmitter.
 - d. Turn on the RMP. The receiver will turn on after the RMP has started up.

Hobby Radio Configuration (cont.)

5. Test the controls.
 - a. Flip the Flap switch to 1 to enter Tractor Mode.
 - b. Push the left joystick up and to the left. This joystick acts as the deadman switch and must be held left and up for the RMP to accept drive commands.
 - c. Use the right stick to command movement.
6. Test the "safe" state.

This test determines what will happen when the RMP loses the radio signal while in use.

 - a. Use the joysticks to command full motion.
 - b. While commanding motion, turn off the transmitter.
 - c. The RMP's wheels should stop moving.



Figure 46: Hobby Radio Controls

NOTICE

If holding the left stick in the upper left corner causes the RMP to move (even when not using the right stick to command movement) follow steps 6 and 7 to adjust the sub-trim and re-bind the transmitter and receiver.

7. Adjust the sub-trim.
 - a. Go to the Adjust List and select Sub-Trim.
 - b. Hold the left stick in the upper left corner.
 - c. Adjust the ailerons until all wheels are moving at the same speed in the same direction.
 - d. Adjust the elevators until all wheels are stopped.
8. Re-bind the transmitter and receiver.
 - a. Repeat the bind procedure (step 3 above) to save these adjusted values.

Table 61: Hobby Radio Controls

Control	Action
Gear Switch	0 = Send Disable command. 1 = Don't send Disable command.
Flap Switch	0 = Standby Mode 1 = Tractor Mode
Left Joystick	Acts as a deadman switch. Disables movement if not held to far left. Disables movement if brought all the way down.
Right Joystick	Controls RMP motion.

Hardware Controls

The RMP is designed to accept hardware Disable and DTZ requests in case of emergency. A Disable request immediately cuts power to the motor drives and turns off the RMP. A DTZ request decelerates the RMP and brings it to a stop, then proceeds as in a Disable request. These modes can also be set via software commands (see "RMP_CMD_SET_OPERATIONAL_MODE," p. 50). CCU J8 provides connections for both signals.

Table 62: CCU J8

J8 Pin	Name
1	+5 V
2	DECEL_REQUEST
3	#DISABLE_5V
4	DGND

Hardware Disable

On the CCU there are four optically isolated outputs (J2, J3, J4, and J5) which allow for control of the hardware disable function on the MCUs inside the Segway powerbases.

Table 63: MCU Hardware Disable

CCU J2, J3, J4, J5	Name
1	Collector (more positive)
2	Emitter (more negative)

The MCUs have a weak pull up resistor such that if the disable input is allowed to float, the MCU will immediately stop providing power to the motors. The CCU prevents this from occurring during normal operation by powering up the diode inside the opto-coupler and thereby connecting the collector to the emitter.

Control of the opto-couplers is accomplished by two different methods:

Method 1 – Internal Segway Logic

At any point if the Segway processor logic needs to immediately disable the system it can do so by releasing one of its DIO lines. This will stop current flowing and prevent the opto-couplers from pulling down on the disable input.

Method 2 – External Disable Signal

The opto-coupler is powered by Pin 3 of J8. +5 V must be provided to Pin 3 of J8 continuously to prevent the CCU from disabling the motor drives. Conveniently, +5 V is provided as an output from the CCU on Pin 1 of J8. Therefore, it is possible to connect a normally closed switch between Pin 3 and Pin 1 to control the disable response. This allows for the simple connection of a Disable Button (such as the one provided with the RMP).

Hardware DTZ

A Decel To Zero (DTZ) can be initiated in hardware via Pin 2 of J8 on the CCU. This signal is normally pulled low by a 10K Ohm resistor. If this pin is pulled up to +5 V then the system will immediately begin to decelerate. The rate of deceleration is set in software; see "RMP_CMD_SET_MAXIMUM_DTZ_DECEL_RATE," p. 44.

Conveniently, +5 V is provided on Pin 1 of J8, allowing the user to easily connect a normally open momentary type switch between Pin 2 and Pin 1 of J8 and control the deceleration request. Segway has found this useful when connecting some types of remote control disable systems.

After the RMP has stopped moving, the system will enter Disable mode and the RMP will shutdown.

Mode Selection

The CCU defaults to normal operation, however, for the purpose of fault troubleshooting or for reloading code the user can change the mode. Mode selection is via CCU J1.

Table 64: CCU J1

J1 Pin	Name	Function
1	BOOT1	Diagnostic Mode
2	BOOT2	Bootloader Mode
3	GND	Ground

Normal Operation

With Pin 1 and Pin 2 both floating, the CCU operates normally. Connecting either Pin 1 or Pin 2 after the system is running will have no effect.

Diagnostic Mode

Connecting Pin 1 to Pin 3 sends the BOOT1 signal. If connected at startup, the CCU will enter Diagnostic mode. For details, see "Diagnostic Mode," p. 26.

Bootloader Mode

Connecting Pin 2 to Pin 3 sends the BOOT2 signal. If connected at startup, the CCU will enter Bootloader mode. For details, see "Bootloader Mode," p. 26. If both pins 1 and 2 are connected to pin 3 (ground), the CCU will enter Bootloader mode.

Status Indicators

There are two status indicators on the CCU that are intended to be connected to LEDs (the Power LED and the Status LED on the UI Panel). On the UI Panel, the Power indicator is a bicolor yellow/red LED and the Status indicator is a green LED. For information on the indicator LEDs and what their patterns mean see "Powering On," p. 29. Status indicators are connected at CCU J16.

Table 65: Status Indicators

J16 Pin	Name
3	Power Indicator (Yellow bicolor LED)
4	Status Indicator (Green LED)
5	Power Indicator (Red bicolor LED)
12	Ground

CCU Input Power

The CCU can receive power from a variety of sources. The table below describes all methods for providing the CCU with power for operation.

Table 66: CCU Input Power Options

Name	DC Voltage	Connection	Min. (V)	Nominal (V)	Max. (V)	~Current Drawn (A)	Charges +7.2 V Battery?	Boots CCU?
+12 V Input	+12	J21 Pin 1 (+) J21 Pin 5 (-)	11	12.0	13	0.150	Yes	Yes
+72 V Input ¹	+72	J6 Pin 6 (+) J6 Pin 4 (-)	45	72	90	0.050	Yes	No
USB Input	+5	J13 Pin 7 (+) J13 Pin 22 (-)	4.5	5	5.5	0.400	No	Yes
Battery Charge	+7.2	J21 Pin 6 (+) J21 Pin 5 (-)	7.2	9	13	0.168	Yes	No
7.2 V Battery	+7.2	J22, see below	5.5	6.6	10	0.273	No	Yes ²

¹ +72 V Input is not currently used by any RMP platform.

² If pins 3 and 4 on J21 are connected.

The CCU is designed so that when a particular voltage is applied all voltages less than that voltage are automatically generated when the board is powered on. For example, when +72 V is applied, the board self generates +12 V, +5 V, +3.3 V, and starts charging the small two-cell battery if present. Small amounts of current can be taken from these supplies to run logic or support circuitry. The user should contact Segway if more than a few Watts are needed from any one supply (see "Contact Information," p. 5).

NOTICE

While the +72 V input can power the entire CCU, it does not have the ability to boot the board without some other voltage being present. That voltage typically comes from the battery supply.

CCU Battery Supply

The CCU can be self-powered from a 7.2 V pack made from two series 3.6 V lithium iron phosphate cells. Use only Segway-approved battery packs. Connection to the CCU is via J22.

Table 67: CCU Battery Supply

J22 Pin	Function
1	+7.2 V (series cell 2)
2	+3.6 V (series cell 1)
3	+ side of 10 K thermistor.
4	- side of 10 K thermistor.
5	Battery return.

The CCU will charge the two-cell battery whenever it has enough power and sufficient voltage to do so. The CCU microprocessors do not need to be powered up for the +7.2 V battery to charge. The microprocessors can be started by connecting J21 Pin 4 to J21 Pin 3. As long as those two pins are connected, the CCU will use the +7.2 V battery pack.

Coin Cell Battery

The coin cell battery on the CCU maintains power to the Real-Time Clock (RTC). If the battery is removed while the RMP is powered off, the RTC will reset. This battery is not user-replaceable. Removing this battery will result in zeroing the clock and will void your warranty.

Included Software

Segway provides demonstration software so that users may test the RMP and see examples of how to communicate with the RMP. The software is provided as an example and is not suitable for controlling the RMP in an unstructured environment. Segway does not warrant or guarantee the performance of this software. Users must create their own software to control the RMP.

The demonstration software provides a reliable configuration that can be used to verify RMP performance during system integration with a new host computer system.

Where to Get the Software

The software is available as a Windows Installer package and is compatible with Windows XP, Windows Vista, and Windows 7.

The installer is available on the forum at <http://rmp.segway.com/forum> in the subforum: "Technical Info for centralized controller based platforms (440LE, 440SE, 220, 210).

Installing the Software

The installer creates a file structure that includes documentation, drivers, and demo applications. Included in the software package are:

- Documentation
- USB drivers
- Bootloader application and release binaries
- OCU demo application and source code
- ABB demo application and source code

The installer also includes Python and all the modules needed to run the demo software from source. Included Python packages are:

- Python 2.7.2
- pygame 1.9.2
- pyserial 2.6
- py2exe 0.6.9

For a more detailed list of what is included in the software package, see `READ_ME_FIRST.pdf` included with the software. That file also includes general instructions on how to use the demo software.

To install the software, run the `RMP_Applications.exe` installer program.

1. Accept the software licence.
2. Select which components to install (default is all components).
3. Specify a destination folder.
The default folder is `C:\Program Files\Segway`
4. Click "Install" to create an `RMP_Applications` subfolder within the destination folder specified.
5. When prompted, install Python and its components.
6. When the installation is complete, click "Finish."

To access the software, use the links on the desktop or the links in the Segway folder in the Start menu.

NOTICE

By installing this software you have agreed to the software licence agreement (`C:\Program Files\Segway\RMP_Applications\Segway_RMP_SW_LICENSE.txt`).

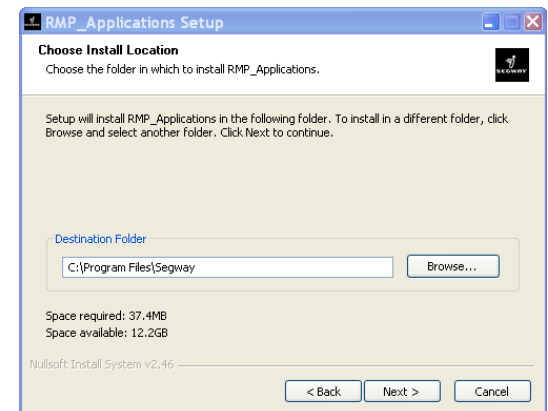

Figure 47: RMP Applications Installer

RMP CCU Bootloader Application

The Bootloader Application allows the user to upgrade the software on the Centralized Control Unit (CCU). The application connects to the bootloader on the CCU and allows the user to upload new software releases to the RMP.

The RMP contains a USB-enabled bootloader for re-flashing both processors. This allows the user to update code as new releases become available. The latest release is located in the installer package and on the RMP forum. It is up to the user to check for the latest installer package.

Software is available at:

- C:\Program Files\Segway\RMP_Applications\Release Binaries
- <http://rmp.segway.com/forum>

There are two bootloaders: one for the Segway Processor (SP), and one for the User Interface Processor (UIP).

Entering Bootloader Mode

1. Turn the RMP off.
2. Connect pins D and F on the 6-pin connector (for the full pinout, see "Connector II," p. 32).
3. Use the USB cable to connect the RMP to the computer. The RMP will power on.
4. Verify that the Power LED is toggling yellow/red and the Status LED is off.

Updating the Software

1. Run the Bootloader application (CCU_BL.exe).
2. Click "Connect."
The bootloader application will connect to the RMP.

NOTICE

If the RMP is not in bootloader mode, an error will pop up (see Figure 50). Ensure that the RMP is in bootloader mode and try again.

3. Click "Select Hex File for Upload".
The file name indicates the board and processor the software was built for, as well as the date of the build and the build number (board_proc.yyyy-mm-dd.build.hex).
4. Browse to and select the relevant hex file (default location: C:\Program Files\Segway\RMP_Applications\Release Binaries).

NOTICE

The Bootloader Application screen should read: "Hex file loaded successfully."

5. Click "Upgrade CCU."
If the same software version is already on the RMP, the message screen will read "The application selected is already loaded!" To upload the file anyway, click "Continue CCU Upgrade."
6. The hex file will be flashed to the ROM.
7. Click "Disconnect" to close the connection with the RMP.

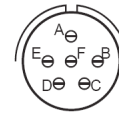

Figure 48: 6-Pin Connector

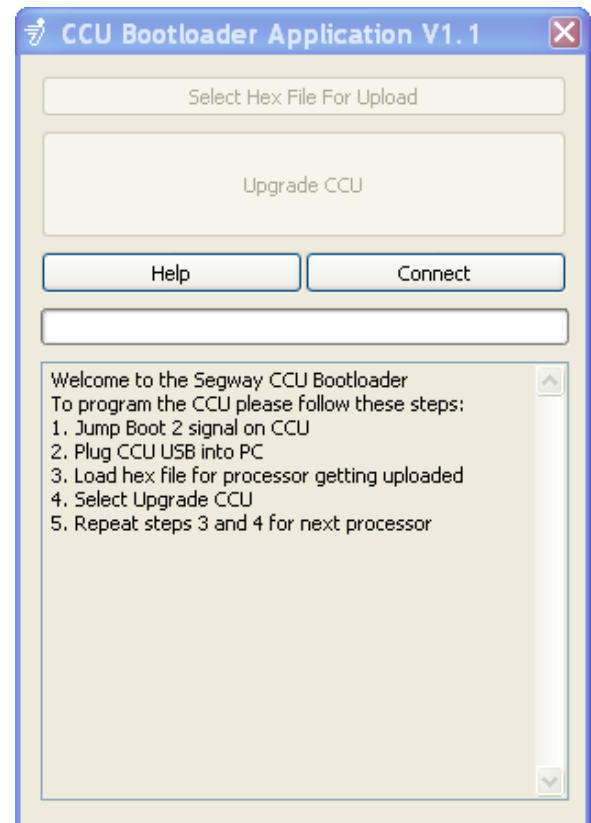

Figure 49: The Bootloader Application

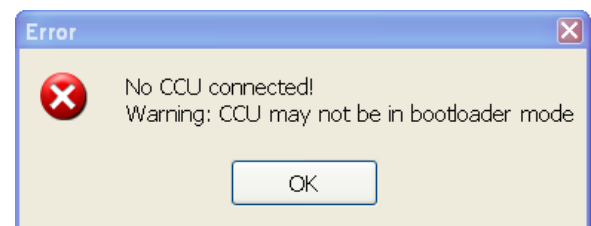

Figure 50: No CCU Connected Error.

OCU Demo Application

The OCU Demo is a functional example of how to interface with the platform. It is not intended to be the end-solution for the customer interface to the RMP platform. Please see the software license agreement ("Software License Agreement," p. 97).

Segway provides the Operator Control Unit (OCU) Demo application with source code that runs on Windows platforms (XP, Vista, 7). The source code illustrates how commands may be constructed and sent to the RMP and how data may be received back and parsed. This application may also be used to check/test the RMP's functionality. The application is not warranted or validated and as such is not suitable for control of the RMP in the user application.

Overview

The OCU Demo application is located in the RMP_Applications folder (default location: C:\Program Files\Segway\RMP_Applications).

When the application launches, the user is greeted with a welcome screen (Figure 51). From here the user can run the OCU, load a configuration file, create and modify configuration files, and extract the faultlog.

Configuration

The software is supplied with a default config (ocu_config_default.inf) with all the parameters set to the default state. It is good practice to leave this file unchanged and create a new config whenever you make any modifications.

If you cannot connect to the RMP at all, it is recommended that you revert to the default config and use a USB connection to upload the config file to the RMP. This is particularly relevant when you do not know what IP address has been set on the RMP.

Changing the Config

1. Run the OCU Demo application.
2. Click "Modify Config".
3. Select a config file.
4. Click through the various screens, taking particular note of the comm interface.
5. Finally, click "Continue" to save the config.
6. Power cycle the RMP to reset the IP address.
7. Use the OCU Demo application to connect to the RMP.

NOTICE

The factory default config can be downloaded from the RMP forum (<http://rmp.segway.com/forum>).

NOTICE

Make sure the physical connection matches the connection specified in the config.

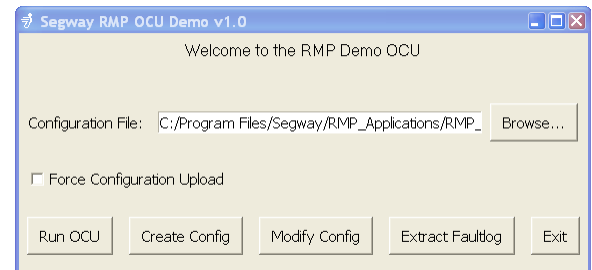

Figure 51: OCU Demo Welcome Screen

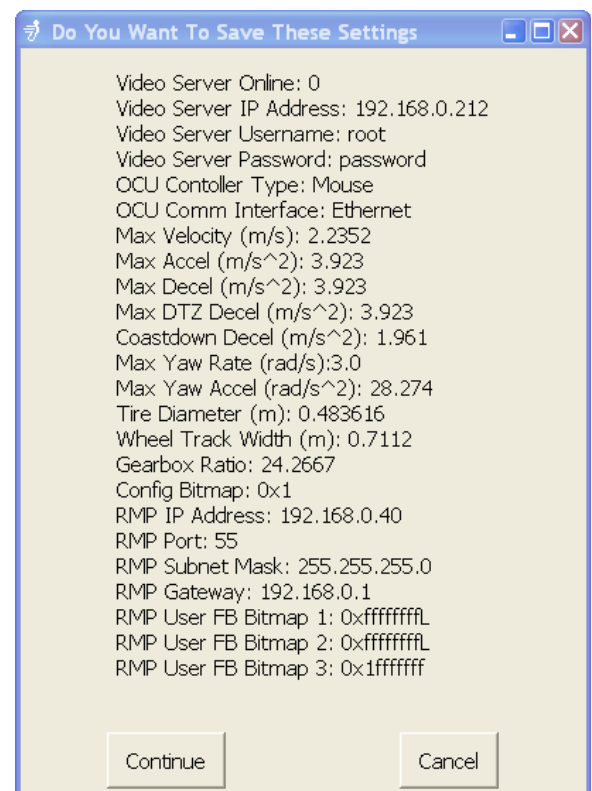

Figure 52: Save or Discard Changes

Configuration Screens

When configuring the RMP, the OCU software walks the user through these screens. Machine-oriented configuration parameters are stored in non-volatile memory on the CCU. The configuration is verified by the OCU Demo at startup. For more information about each of the configuration settings, see "Configuration Commands," p. 42.

Video Server

Allows the OCU Demo to connect to a video server on the local camera (e.g. an IP camera). Video is displayed on the splash screen instead of the Segway logo.

Controller

Allows the user to choose how to control the RMP. Options are: Xbox 360 controller, Logitech GamePad/RumblePad, Mouse, or Keyboard. Only one controller may be used at a time.

Comm Interface

Defines which interface the OCU Demo communicates over. The RMP always communicates over all 3 interfaces; this setting only affects the OCU Demo application.

Performance

Defines all the user-configurable dynamic characteristics of the machine. Sets the maximum velocity, acceleration rates, deceleration rates, turning rate, and other similar parameters.

Machine Parameters

Defines the physical characteristics of the RMP that are used for calculating odometry and inertial estimates.

Input Mapping

Defines how various commands and actions are interpreted by the RMP.

Network Settings

Provides the IP, port, subnet, and gateway settings for the RMP to use. Network settings do not go into effect until the RMP restarts.

Feedback

Determines which parameters the RMP will provide when asked for a status update. Any item not included is not sent by the RMP when responding to status requests.

Confirmation

Provides a summary of the settings and allows the user to save the config or discard the changes.

Extracting the Fault Log

On the OCU Demo welcome screen (Figure 51, p. 92) there is a button for extracting the fault log from the RMP. Pressing this button will open a connection with the RMP and save the fault log to your computer.

1. Click "Extract Faultlog."
2. Select your connection interface.
3. Select a save location.
Default location is C:\Program Files\Segway\RMP_Applications\RMP_Demo_OCU_Application\RMP_CCU_FAULTLOGS

The fault log is saved as an html file. Faults are listed in the order they appear in the fault log, not in the order in which they have occurred.

NOTICE

The Real Time Clock (RTC) does not take into account daylight savings time. The RTC is set to Eastern Daylight Time.

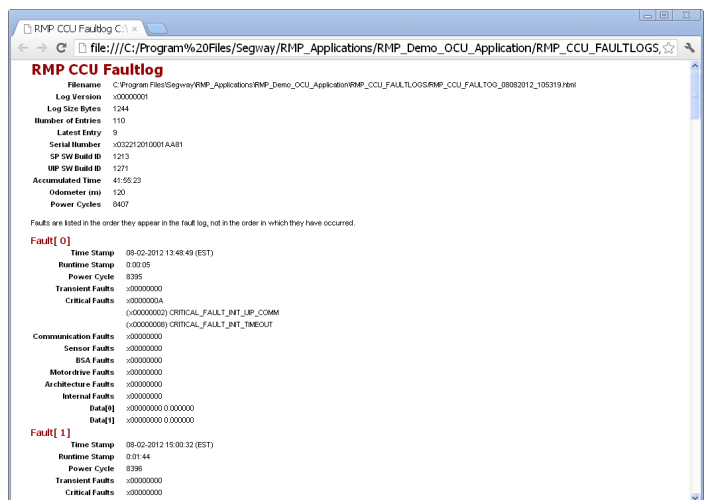

Figure 53: Fault Log

Running the OCU Demo

Clicking "Run OCU" will cause the OCU Demo to attempt to connect to the RMP. The default method of connecting is via Ethernet (see "Ethernet," p. 34), but this can be changed in the config (see "Configuration," p. 92).

When the OCU Demo is up and running, three windows appear:

- Splash Screen
- Console
- Control Screen

Splash Screen

The splash screen (Figure 54) displays the mode of the RMP, the uptime, and the battery status. If a video server (e.g. IP camera) is configured, the video feed is displayed here.



Figure 54: Splash Screen

Console

The console (Figure 55) displays the status of the many variables and parameters (for more information about these parameters, see "RMP Response," p. 56).

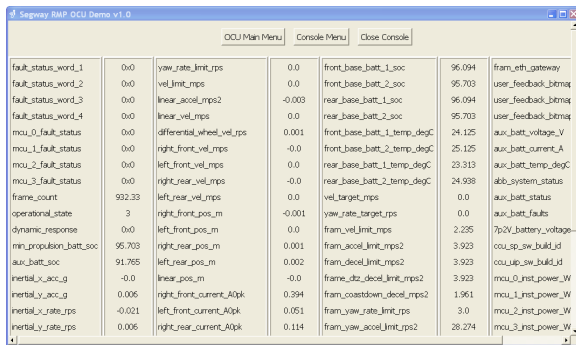

Figure 55: Console

The data displayed can be set either in the config or in the Console Menu. The config file tells the RMP what to include and what to omit when responding to status requests. The Console Menu allows the user to determine what data is displayed on the screen; it does not stop the data from being sent.

The console also includes a logging function. Only those messages that are displayed in the console are logged. Disabling display of a function also disables logging of that function.

Control Screen

The control screen (Figure 56) contains buttons for changing modes, shutting down, disabling, and decelerating the RMP. It also has a button for making noise, which will cause the RMP to chirp. This screen provides a method for controlling the RMP. Shown here is the method of controlling the RMP with the mouse. For more information on how to control the RMP, see "Controls," p. 95.

NOTICE

The Balance Mode button will only cause a mode transition if Balance Mode is available and the transition is allowed.

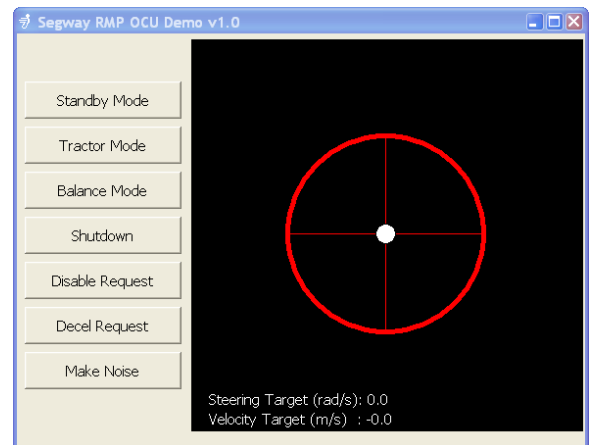

Figure 56: Control Screen

Controls

The RMP can be controlled in a wide variety of ways. Segway provides some example control interfaces that are compatible with the Demo OCU, but many other methods are possible.

⚠ WARNING

The RMP can accelerate rapidly, risking personal injury and/or property damage. It is recommended that the RMP be securely raised so the wheels are off the ground until the user becomes familiar with the controls.

Table 68: OCU Demo Controls

Command	Keyboard	Mouse	Xbox 360	Logitech GamePad
Exit OCU			Start	9
Power Down	1	GUI Button	Back	10
Standby Mode	2	GUI Button	B	3
Tractor Mode	3	GUI Button	X	1
Balance Mode	4	GUI Button	Y	4
Decelerate	Backspace	GUI Button	Left Bumper	5
Disable	Delete	GUI Button	Right Bumper	6
Audio Song		GUI Button	A	2
Deadman Switch	Spacebar	Mouse Click	Left Trigger	7
Forward/Backward	Up/Down Arrows	Drag Up/Down	Left Stick Up/Down	Left Stick Up/Down
Turn Left/Right	Left/Right Arrows	Drag Left/Right	Right Stick Left/Right	Right Stick Left/Right

Keyboard

The keyboard controls in the OCU Demo are very simple. Numbers 1-4 are used to switch modes and the arrow keys are used for movement and turning.

Spacebar acts as a deadman switch; you must hold down the spacebar while pressing the arrow keys for the RMP to move.

Pressing and holding an arrow key will cause the RMP to move at increasing speed.

Mouse

When the mouse interface is chosen, the OCU Demo creates an additional GUI window. Buttons provide a click-friendly way of switching between modes and issuing commands.

A pair of crosshairs with a circle at the intersection provide the interface for moving the RMP. Click and drag the circle up and down to move the RMP forward and back. Drag it left and right to turn. Moving the circle farther from center increases the speed at which the RMP moves.

Xbox 360

The OCU Demo application allows the RMP to be controlled by an Xbox 360 controller (wired or wireless). In this configuration the left stick is used for controlling forward and reverse movement. The right stick is used for turning. The user must hold the deadman switch (Left Trigger) to make the RMP move at all.

Switching between modes (for more on modes, see "Operational Model," p. 24) is accomplished by the X and B buttons. Pressing A will initiate an audio song (for more on audio songs, see "RMP_CMD_SET_AUDIO_COMMAND," p. 50).



Figure 57: Xbox 360 Controls

Logitech GamePad/RumblePad

The OCU Demo can be set to use a Logitech GamePad (wired or wireless) to control the RMP. The Logitech GamePad looks and acts very similar to the Xbox 360 controller. The major difference is in the location of the sticks.

Just like with the Xbox 360 controller, the left stick is used for controlling movement forward and reverse. The right stick is used for turning. The user must hold the deadman switch to make the RMP move at all.

Switching between RMP modes is accomplished by the 1, 3, and 4 buttons. Pressing 2 will initiate an audio song (for more on audio songs, see "RMP_CMD_SET_AUDIO_COMMAND," p. 50).

NOTICE

The Logitech controller has a mode button on the front center of the controller. The mode light must be off to control the RMP's movement.



Figure 58: Logitech GamePad Controls

Software License Agreement

COPYRIGHT © 2013 SEGWAY INC.

Software License Agreement:

The software supplied herewith by Segway Inc. (the "Company") for its RMP Robotic Platforms is intended and supplied to you, the Company's customer, for use solely and exclusively with Segway RMP products. The software is owned by the Company and/or its supplier, and is protected under applicable copyright laws. All rights are reserved. Any use in violation of the foregoing restrictions may subject the user to criminal sanctions under applicable laws, as well as to civil liability for the breach of the terms and conditions of this license. The Company may immediately terminate this Agreement upon your use of the software with any products that are not Segway products.

The software was written using Python programming language. Your use of the software is therefore subject to the terms and conditions of the OSI-approved open source license viewable at <http://www.python.org/>. You are solely responsible for ensuring your compliance with the Python open source license.

You shall indemnify, defend and hold the Company harmless from any claims, demands, liabilities or expenses, including reasonable attorneys fees, incurred by the Company as a result of any claim or proceeding against the Company arising out of or based upon:

- (i) The combination, operation or use of the software by you with any hardware, products, programs or data not supplied or approved in writing by the Company, if such claim or proceeding would have been avoided but for such combination, operation or use.
- (ii) The modification of the software by or on behalf of you.
- (iii) Your use of the software.

THIS SOFTWARE IS PROVIDED IN AN "AS IS" CONDITION. NO WARRANTIES, WHETHER EXPRESS, IMPLIED OR STATUTORY, INCLUDING, BUT NOT LIMITED TO, IMPLIED WARRANTIES OF MERCHANTABILITY AND FITNESS FOR A PARTICULAR PURPOSE APPLY TO THIS SOFTWARE. THE COMPANY SHALL NOT, IN ANY CIRCUMSTANCES, BE LIABLE FOR SPECIAL, INCIDENTAL OR CONSEQUENTIAL DAMAGES, FOR ANY REASON WHATSOEVER.

Maintenance

To ensure that your RMP continues to function optimally, please follow these routine maintenance guidelines.

WARNING!

- Before performing any maintenance, verify that the Segway RMP is unplugged and powered off. It is not safe to perform maintenance while the RMP is powered on or charging. The RMP could move unexpectedly, causing death, serious injury, or property damage.
- Use only Segway approved fasteners on the RMP. Other fasteners may not perform as expected and may come loose. Failure to do so could lead to risk of serious injury, death, or property damage.
- Always use thread lock on fasteners to keep them from coming loose. Failure to do so could lead to serious injury, death, or property damage.
- Insert fasteners slowly and carefully. Do not cross-thread or over-tighten fasteners. Tighten only to the prescribed torque. Failure to do so could affect the RMP's behavior and may cause serious injury, death, or property damage.
- Do not attempt to repair any stripped or damaged screw hole. Instead, replace the part. If a replacement part is not available, do not reassemble. Failure to do so could lead to serious injury, death, or property damage.

Fastener Torque

CAUTION!

Adhere to torque specifications when tightening fasteners. Over-tightening or under-tightening fasteners can result in damage to the RMP or malfunction.

Periodically check the fastener torques. Fastener torque specifications are provided in Table 69.

Table 69: 440 SE Fastener Torque Specifications

Fastener Location	Fastener Type	Drive Type	Torque
Wheel Nut	M8 Flange Nut	13 mm Hex	35 N-m
Hub Adapter	M10 x 22 SHCS	8 mm Hex	30 N-m
Battery Fastener	M4 x 30 SHCS	3 mm Hex	1.6 N-m
Enclosure Cover	M5 x 10 FHCS	3 mm Hex	3 N-m
Enclosure to Bracket	M6 x 12 SHCS	5 mm Hex	6 N-m
Bracket to Rail	M8 x 25 SHCS	6 mm Hex	10 N-m
Gearbox	M8 x 34 SHCS	T45 Torx	40 N-m

Tire Pressure

Ideal tire pressure for the supplied tires depends on both the surface being driven across and the payload being carried. Because every situation is different, Segway recommends keeping the tire pressure within the range of 6–12 psi. Do not allow the tire pressure to exceed what's stated on the sidewall of the tire.

To ensure that the RMP tracks straight, all tires must be inflated to the same pressure.

When inflating tires to a different pressure, be sure to update the tire diameter (see "RMP_CMD_SET_TIRE_DIAMETER," p. 45). The tire diameter is used internally when calculating velocity, acceleration, position, and differential wheel speed.

Parts List

Use the diagram and table below to identify part names and numbers.

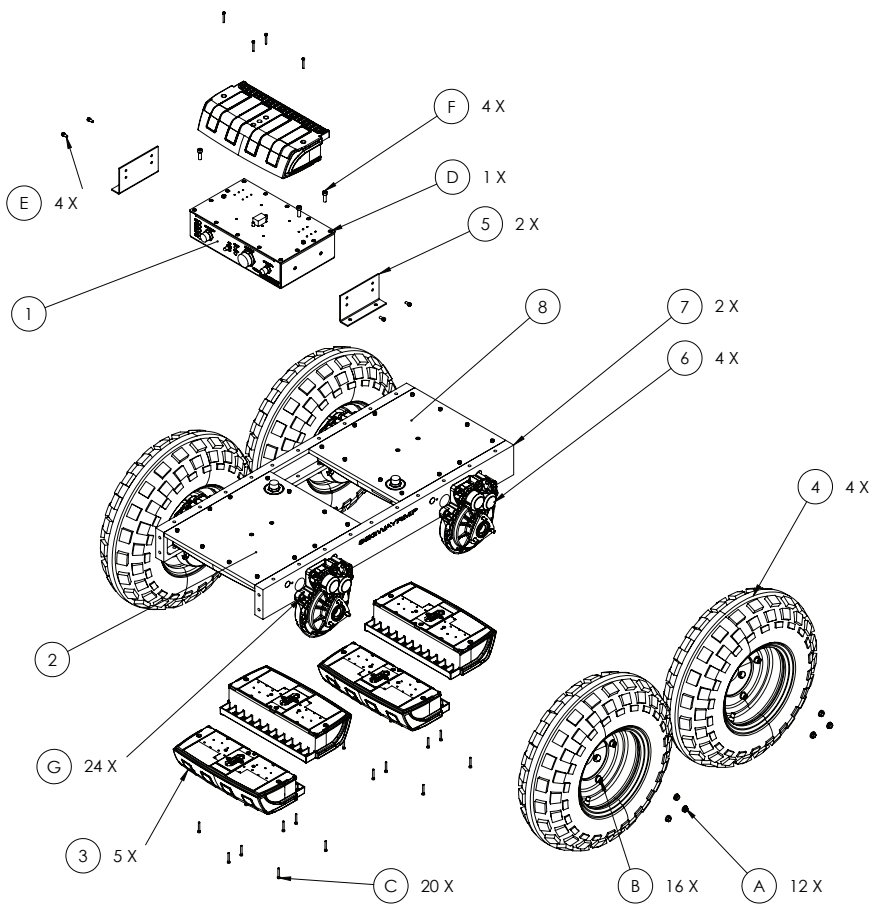

Figure 59: RMP 440SE Parts Breakdown

Table 70: 440 SE Components

Label	Name	Part No.	Description
1	Enclosure	23271-00001	UI Module
2	Rear Powerbase	23088-00002	2M
3	Battery	20967-00001	Li-ion
4	Wheel Assembly	23378-00001	Tire and Hub
5	Bracket	23286-00001	Standard
6	Gearbox	20919-00002	Standard
7	Rail	23277-00001	Inverted
8	Front Powerbase	23088-00001	2MB

Table 71: 440 SE Fasteners

Label	Fastener Location	Part No.	Description
A	Wheel Nut	20158-00001	M8 Flange Nut
B	Hub Adapter	20991-00001	M10 x 30 SHCS
C	Battery	20541-00002	M4 x 30 SHCS
D	Enclosure Cover	23313-00001	M5 x 10 FHCS
E	Enclosure to Bracket	23091-00004	M6 x 12 SHCS
F	Bracket to Rail	23368-00002	M8 x 25 SHCS
G	Gearbox	20537-00001	M8 x 34 SHCS

Removing Wheel Assemblies

1. Make sure the RMP is powered off and unplugged.
2. Raise the RMP up so the tires are not touching the ground.
3. Loosen the three wheel nuts that connect the hub adapter to the gearbox flange.
4. The tire/hub assembly can now be removed.

Replacing Wheel Assemblies

1. Make sure the RMP is powered off and unplugged.
2. Raise the RMP up off the ground.
3. Slide the tire/hub assembly onto the gearbox flange so the three fasteners on the gearbox flange fit through the holes in the tire hub.
4. Install the three wheel nuts using a torque wrench with a 13 mm hex bit and tighten to **35.0 N-m (25.8 ft-lbf)**.

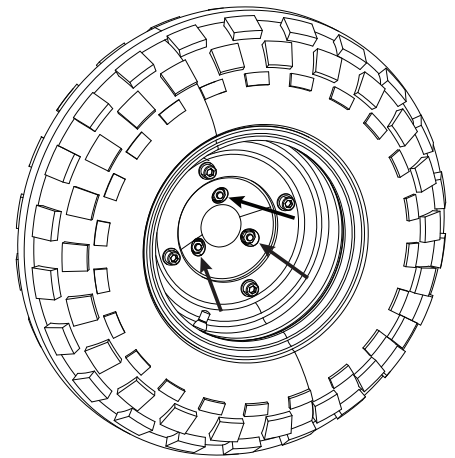

Figure 60: Wheel Nut Locations

Cleaning

⚠ WARNING!

Do not use a power washer or high pressure hose to clean your RMP. Use of these devices could force water into components that must stay dry. See "Safety," p. 7, for more information. Failure to do so could expose you to electric shock, injury, burns, or cause a fire.

The outside of the RMP can be cleaned by scrubbing with soap and water to remove any dirt and grime. Avoid getting water in the connectors. Do not submerge in water.

If the inside of the RMP needs to be cleaned, contact Segway (see "Contact Information," p. 5). Do not use water or any liquid cleaning agents inside the enclosure.

Software Updates

Periodically, Segway releases new software updates for the RMP. New software may improve performance and/or change how the RMP functions. Always read the release notes before upgrading. Some upgrades may require users to change their user-created software as well.

To check if a software update is available, go to the RMP forum at <http://rmp.segway.com/forum/> and click on the subforum titled "Technical Info for centralized controller based platforms (440LE, 440SE, 220, 210)". Software releases are posted as announcements at the top of the subforum.

Batteries

A pair of propulsion batteries mount to the bottom of each powerbase. An auxiliary battery mounts to the enclosure.

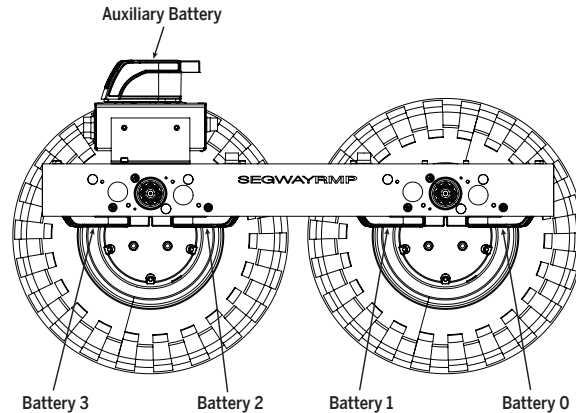

Figure 61: Battery Locations

Replacing Batteries

Whenever you replace a propulsion battery, consider replacing all propulsion batteries. Replacing only one battery will not necessarily increase the performance or range of your Segway RMP because the Segway RMP is designed to operate only at the level allowed by the lower-energy battery. Therefore, you should replace all propulsion batteries together (except in the unusual situation where a battery is replaced because of damage or defect and the others are relatively new).

Table 72: Lithium-ion Battery Specifications

Characteristic	Value
Charging Time	
Before First Use	12 hours
Recharge From Empty (w/o Smart Charger Board)	~8 hours
Recharge From Empty (w/ Smart Charger Board)	~2 hours
Temperature Ranges	
Operating	32° F – 122° F (0° C – 50° C)
Charging	50° F – 122° F (10° C – 50° C)
Storage and Transport	-4° F – 122° F (-20° C – 50° C)
General	
Capacity (Ah) and Voltage	5.2 Ah, 73.6 volts
Dimensions	14 in x 7.5 in x 3.2 in (35.7 cm x 19 cm x 8.2 cm)
Weight	11.4 lbs (5.1 kg)

NOTICE

For RMPs without Smart Charger Boards: do not leave your RMP plugged in and charging indefinitely. Unplug and plug back in at least once a month. Leaving batteries plugged in for an extended period of time could result in one or more dead batteries.

Installation and Removal Instructions

WARNING!

Unplug or disconnect your Segway RMP from AC power before removing or installing batteries or performing any service. It is hazardous to work on any part of your RMP when it is plugged into AC power. You risk serious bodily injury from electric shock as well as damage to your RMP.

Install and remove the batteries in a dry location only.

Removing Batteries

Tool required: 3 mm hex wrench.

1. Tip the RMP onto its side so the outside two wheels lay flat against a clean, smooth surface.
2. Use a 3 mm hex wrench to remove fasteners (4 per battery).
3. Pull batteries straight off chassis.

Installing Batteries

CAUTION!

Replace battery fasteners every time a battery is installed. Use only Segway-approved fasteners. Failure to replace fasteners jeopardizes the watertight seal of the RMP.

Tool required: 3 mm hex wrench.

1. Tip the RMP onto its side so the outside two wheels lay flat against a clean, smooth surface.
2. Seat batteries on chassis with curved edge facing outside of chassis.
3. Secure batteries to chassis with fasteners (4 per battery, install center fasteners first) and tighten with 3 mm hex wrench. Torque fasteners to **1.6 N-m (1.18 lb-ft)**.

NOTICE

Do not cross thread or over-tighten fasteners. Tighten only to the prescribed torque. To avoid risk of damage, do not use a power tool to thread in or tighten fasteners. Use only Segway-approved fasteners.

Transportation and Shipping

Lithium-ion batteries are regulated as "Hazardous Materials" by the U.S. Department of Transportation. For more information, contact the U.S. Department of Transportation at <http://www.phmsa.dot.gov/hazmat/regs> or call 1-800-467-4922.

Proper Disposal

The Li-ion batteries used in the Segway RMP can be recycled. Recycle or dispose of batteries in accordance with local environmental regulations. Do not place in fire or incinerate. For more information, contact Segway at 1-866-4SEGWAY (1-866-473-4929), or visit our website at <http://rmp.segway.com>.

Troubleshooting

This section covers common problems and their solutions.

Reporting Problems to Segway

The RMP forum (<http://rmp.segway.com/forum>) is the best way to contact Segway about troubleshooting issues and problems. See "Contact Information," p. 5. Please search the forum before posting; your issue may have been discussed previously.

To ensure a prompt and helpful response from Segway, please include the following when posting to the forum:

- Upload a copy of the fault log. See "Extracting the Faultlog" below.
- Explain what you were doing when the fault occurred.
- What is the model number of your RMP?
- How much mass (weight) was on the RMP?
- What surface/slope was the RMP on?
- What were the environmental conditions (temperature/humidity)?
- Have you modified the RMP?

Extracting the Faultlog

Follow these instructions to extract the faultlog from your RMP. By entering Diagnostic Mode, you can extract the faultlog even if the RMP won't startup successfully.

Enter Diagnostic Mode

1. Turn the RMP off.
2. Connect pins D and E on the 6-pin connector (Connector II).
3. Use the USB cable to connect the RMP to the computer. The RMP will power on.

Extract the Faultlog

1. Double-click "RMP_OCU_Demo" on the desktop.
2. Click "Extract Faultlog."
3. Select "USB" and click "Next."
4. Click "OK."
5. The faultlog will open in your web browser.
6. Disconnect the USB cable. The RMP will power off.

Reading the Faultlog

The faultlog is arranged with a header at the top and the 20 most recent faults below. The first fault logged is recorded as Fault[0], the second fault as Fault[1] and so on until the 20th fault is recorded as Fault[19]. At this point there are no empty slots remaining in the faultlog, so the 21st fault overwrites Fault[0]. Similarly, the 22nd fault overwrites Fault[1] in the log. This process continues indefinitely so that only the latest 20 faults are present in the log.

For your convenience the latest entry is listed in the header. In the example below the latest entry is 4, so Fault[4] is the most recent fault.

If a fault provides more information, that information is available in Data[0] and Data[1]. Often these contain bitmaps which can be decoded to provide additional information.

RMP CCU Faultlog

Filename C:\Program Files\Segway\RMP_Applications\RMP_Demo_OCU_Application\RMP_OCU_FAULTLOGS\RMP_OCU_FAULTLOG_11212012_105208.html

Log Version x00000001

Log Size Bytes 1244

Number of Entries 5

Latest Entry 4

Serial Number x111312020001AB81

SP SW Build ID 1224

UIP SW Build ID 1274

Accumulated Time 2:16:06

Odometer (m) 2508

Power Cycles 21

Faults are listed in the order they appear in the fault log, not in the order in which they have occurred.

Fault[0]

Time Stamp 11-15-2012 15:05:35 (EST)

Runtime Stamp 0:09:41

Power Cycle 5

Transient Faults x00000000

Critical Faults x00000000

Communication Faults x00000000

Sensor Faults x00000000

BSA Faults x00000000

Motordrive Faults x00000000

Architecture Faults x00000010
(x00000010) ARCHITECT_FAULT_COMMANDED_SAFETY_SHUTDOWN

Internal Faults x00000000

Data[0] x00000000 0.000000

Data[1] x00000004 0.000000

Figure 62: Faultlog Example 1

Fault[4] (Latest Entry)

Time Stamp 11-19-2012 15:34:13 (EST)

Runtime Stamp 0:32:16

Power Cycle 18

Transient Faults x00000000

Critical Faults x00000000

Communication Faults x00000000

Sensor Faults x00000000

BSA Faults x00000000

Motordrive Faults x00000000

Architecture Faults x00000040
(x00000040) ARCHITECT_FAULT_KILL_SWITCH_ACTIVE

Internal Faults x00000000

Data[0] x00000004 0.000000

Data[1] x00000000 0.000000

Fault[5]
empty

Fault[6]
empty

Fault[7]
empty

Fault[8]
empty

Fault[9]
empty

Fault[10]
empty

Fault[11]
empty

Figure 63: Faultlog Example 2

Faults

Descriptions of the most common faults are provided below. These descriptions may provide sufficient information for users to solve problems on their own. As always, if you need help please see "Reporting Problems to Segway," p. 103.

The RMP stores all faults in four 32-bit fault status words. Fault status can be transmitted as part of the RMP response (see "RMP Response," p. 56). Faults are sent as part of User Defined Feedback Bitmap 1.

CRITICAL_FAULT_INIT_PROPULSION

There is a problem initializing the propulsion system. Make sure everything is properly connected, the batteries are charged, and the RMP is resting on a level surface.

CRITICAL_FAULT_FORW_SPEED_LIMITER_HAZARD

System speed exceeds the user-defined forward limit. If speed limit is set to zero and RMP is moved, you may see this fault.

CRITICAL_FAULT_AFT_SPEED_LIMITER_HAZARD

System speed exceeds the user-defined reverse limit. If speed limit is set to zero and RMP is moved, you may see this fault.

CRITICAL_FAULT_CHECK_STARTUP

There was a fault during startup. The output of Data[0] indicates the specific fault that occurred.

Table 73: Startup Faults

Data[0]	Meaning
0x00000001	One of the MCUs has faulted.
0x00000002	The RMP is plugged in and the "Check AC Present" flag is set.
0x00000004	Low battery voltage – attempt to charge the system.
0x00000008	Low battery voltage – attempt to charge the system.
0x00000010	The system must be stationary during startup. Movement was detected.

CRITICAL_FAULT_APP_VELOCITY_CTL_FAILED

This indicates that the RMP is moving at a different speed than what was commanded for a period of time. This can occur if you are commanding zero velocity while towing the RMP.

Faults (cont.)

CRITICAL_FAULT_ABB_SHUTDOWN

This indicates that the ABB experienced a fault. The response will include four bitmaps: ABB Status, Battery Hazards, Battery Faults, and Build ID. All four of these bitmaps are packed into the two Data bitmaps in the faultlog. They are arranged as such:

ABB Status Data[0] High
 Battery Hazards Data[0] Low
 Battery Faults Data[1] High
 Build ID Data[1] Low

The following tables provide the bitmaps for ABB Status (Data[0] High) and Battery Hazards (Data[0] Low). If Battery Faults (Data[1] Low) is anything other than 0x0000, contact Segway to purchase a replacement battery.

The mask for ABB Status Bitmap is 0x1FFF000 on Data[0].

Table 74: ABB Status Bitmap (Data[0] High)

Bit	Name	Description	Action
0x0000	ABB_OK	ABB is operational.	None.
0x0001	BCU_COMM_INIT_TIMEOUT	The ABB was not able to start communications with the battery BCU.	Check ABB connection to battery.
0x0002	LOW_BATTERY_SOC	The battery State Of Charge is lower than 5%.	Charge the battery.
0x0004	LOW_BLOCK_VOLTAGE	Battery has detected low block voltage internally on one of its banks.	Charge the battery. If this error occurs frequently, replace the battery.
0x0008	BATTERY_IS_HOT	The internal battery temperature is too high for operation.	Turn off the RMP and let the battery cool down.
0x0010	BATTERY_IS_COLD	The internal battery temperature is too low for operation.	Turn off the RMP and warm the battery up.
0x0020	INTERNAL_BCU_FAULT	Internal Battery Control Unit fault.	Replace the battery.
0x0040	LOW_PACK_VOLTAGE	Battery pack voltage has dropped below its operating range.	Charge the battery.
0x0080	ABB_OVER_CURRENT	ABB has detected that the current draw has exceeded the fuse rating for a period of time.	Reduce external load. Check for shorts.
0x0100	BCU_LINK_FAILED	Communication between the ABB and the BCU has failed.	Check the connection between the ABB and battery.
0x0200	ABB_HIT_INTERNAL_FAULT	The ABB has reached points in the software it should not.	Report to Segway.
0x0400	ABB_HOST_COMMANDS_SHUTDOWN	The Host has commanded the ABB to shutdown.	None. If it was unintentional check the host code.
0x0800	ABB_GOING_TO_SHUTDOWN	A condition has triggered the ABB to shutdown.	Check the condition in this bitmap.
0x1000	AC_IS_PRESENT	The ABB has detected that a charger is connected and charging the battery.	This is informational only.

Faults (cont.)

The mask for Battery Hazards is 0x0000EE00 on Data[0].

Table 75: Battery Hazard Bitmap (Data[0] Low)

Bit	Name	Description	Action
0x0000	BCU_NO_HAZARD	ABB is operational.	None.
0x0200	BATTERY_COLD_CHARGE_LIMIT_HAZARD	The battery is too cold to charge.	Move the battery to a warmer place to charge.
0x0400	BCU_BATTERY_COLD_HAZARD	The battery is too cold to operate.	Turn off the RMP and warm the battery up.
0x0800	BCU_BATTERY_COOL_HAZARD	The battery is approaching the threshold for cold operation.	Move the battery to a warmer place.
0x2000	BCU_BATTERY_LOW_BLOCK_VOLTAGE_HAZARD	A battery bank voltage has dropped below its operating range.	Charge the battery. If this error occurs frequently, replace the battery.
0x4000	BCU_BATTERY_HOT_HAZARD	The internal battery temperature is too high for operation.	Turn the RMP off and let the battery cool down.
0x8000	BCU_BATTERY_WARM_HAZARD	The battery is approaching the threshold for hot operation.	Move the battery to a cooler place.

SENSOR_FAULT_7P2V_VBAT_RANGE_FAULT

The voltage differential between the two cells in the 7.2 V battery exceeds the allowed threshold. Replace the battery.

SENSOR_FAULT_7P2V_VBAT_INBALANCE_FAULT

Something is wrong with the 7.2 V battery. Charge the RMP for 24 hours. If the error persists, replace the battery.

SENSOR_FAULT_7P2V_BATT_TEMPERATURE_FAULT

Battery temperature has gone outside the recommended range. See the RMP operating temperature range ("Environmental Specifications," p. 17). Physically inspect the battery for damage.

BSA_FAULT_SIDE_A_RATE_SENSOR_SATURATED

The RMP has exceeded the acceleration rate threshold (0.7 g). If driving over rough terrain, do so more slowly.

BSA_FAULT_SIDE_B_RATE_SENSOR_SATURATED

The RMP has exceeded the acceleration rate threshold (0.7 g). If driving over rough terrain, do so more slowly.

BSA_FAULT_SIDE_A_TILT_SENSOR_SATURATED

The RMP has exceeded the tilt rate threshold (6.2 rad/s). If driving over rough terrain, do so more slowly.

BSA_FAULT_SIDE_B_TILT_SENSOR_SATURATED

The RMP has exceeded the tilt rate threshold (6.2 rad/s). If driving over rough terrain, do so more slowly.

ARCHITECT_FAULT_COMMANDED_DISABLE

The RMP received a user-commanded disable signal. See "RMP_CMD_SET_OPERATIONAL_MODE," p. 50.

ARCHITECT_FAULT_COMMANDED_SAFETY_SHUTDOWN

The RMP received a user-commanded DTZ signal. See "RMP_CMD_SET_OPERATIONAL_MODE," p. 50.

ARCHITECT_FAULT_DECEL_SWITCH_ACTIVE

The hardware DTZ button has been pressed.

Faults (cont.)

ARCHITECT_FAULT_KILL_SWITCH_ACTIVE

The disable button has been pressed, or is not present.

ARCHITECT_FAULT_BAD_MODEL_IDENTIFIER

The wrong code is loaded in the machine. Check the serial number in the fault log header against the serial number on the RMP. The last 7 bits of the serial number on the RMP should match the last 7 bits of the serial number in the fault log.

MCU_TRANS_BATTERY_TEMP_WARNING

This fault occurs as the battery temperature approaches the limit. See the RMP operating temperature range ("Environmental Specifications," p. 17).

MCU_CRITICAL_BATTERY_TEMP

This fault occurs when the battery temperature reaches or exceeds the limit. See the RMP operating temperature range ("Environmental Specifications," p. 17). Physically inspect the battery for damage.

MCU_TRANS_BATTERY_COLD_REGEN

As temperature drops battery resistance increases, which in turn increases the current required for regeneration. The battery has a limit for regeneration current under low temperatures. Warm up the battery or move the RMP inside.

MCU_TRANS_BATTERY_LOW_BATTERY

The battery is low. Charge the battery.

MCU_TRANS_BATT_OVERVOLTAGE

The RMP will generate power when driving downhill. This fault occurs when the voltage approaches the threshold for damage.

MCU_CRITICAL_BATT_OVERVOLTAGE**⚠ WARNING!**

Avoid contact with any substance seeping from the battery. Do not use battery if the battery casing is broken or if the battery emits an unusual odor, smoke, or excessive heat or leaks any substance.

Similar to MCU_TRANS_BATT_OVERVOLTAGE, the RMP will generate power when driving downhill. This fault occurs when the voltage reaches or exceeds the threshold for damage. Physically inspect the battery for damage.

MCU_COMM_CU_BCU_LINK_DOWN

A connection to the battery cannot be reliably established. Check to make sure the battery is properly connected and the fasteners are fully tightened. For proper torque see "Maintenance," p. 98.

MCU_JUNCTION_TEMP_FAULT

You may be overloading the RMP. Try reducing the payload mass. See the RMP operating temperature range ("Environmental Specifications," p. 17).

MCU_MOTOR_WINDING_TEMP_FAULT

The motor temperature has reached or exceeded the threshold for damage. Try reducing the payload mass. See the RMP operating temperature range ("Environmental Specifications," p. 17).

MCU_BATTERY_FAULT

The battery has an internal error. Replace the battery.

MCU_ACTUATOR_POWER_CONSISTENCY_FAULT

The RMP is operating at its limits. Reduce the performance parameters. Reduce the mass on the RMP.

Charging Faults

If the Charge Status LEDs blink red, there is a fault with the battery. The following table provides the meanings of the blink patterns and some suggested actions.

Table 76: Battery Charging Faults

LED Status	Meaning	Action
Red blink 1 time every 5 seconds.	HV input is out of range.	Check charger connection. If problem persists contact Segway.
Red blink 2 times every 5 seconds.	HV output is out of range.	Check connections to the powerbase.
Red blink 3 times every 5 seconds.	DC reference is out of range.	Contact Segway.
Red blink 4 times every 5 seconds.	Temperature is out of range.	Move the platform to a warmer or cooler area. If problem persists contact Segway.
Red blink 5 times every 5 seconds.	Output current is out of range.	Contact Segway.

Other Issues

RMP doesn't drive in a straight line.

Check the tire pressures on your RMP. Slight differences in pressure can cause changes in tire diameter, which can cause the RMP to track right or left.

RMP still doesn't drive straight.

If you are using a joystick or hand-held controller, check if it is sending slight yaw rate signals even when not commanded to. Some joysticks do not hold center very well and will continuously send small signals.

Cannot communicate with RMP over Ethernet.

1. Power cycle the RMP (turn off, then turn on). This verifies that all Ethernet settings are updated.
2. Ping the RMP (e.g. "ping 192.168.0.40"). This verifies that there is a path to the RMP and that you are using the correct IP address.
3. Check the port settings. The RMP will send and receive commands only on the port specified by "RMP_CMD_SET_ETH_PORT_NUMBER," p. 47.

